

# **Cikada**

Ride with a Smile

## **Cikada Touring E-Bike User Manual**

# **QR Code for Easy Scanning**



Cikada E-bike Registration

How to - Cikada Tips & Guides

E-Bike Setup Video

Riding Tutorial

# TABLE OF CONTENTS

<u>Registering your Product (to extend the Frame Warranty)</u>	<u>4</u>
<u>Important Safety/General Instructions</u>	<u>5</u>
<u>Recharging the Battery and Safety Instructions</u>	<u>12</u>
<u>E-Bike Product Specifications</u>	<u>12</u>
<u>E-Bike Assembly Guide</u>	<u>13</u>
<u>E-Bike Display Instructions</u>	<u>15</u>
<u>Anatomy of your E-Bike</u>	<u>18</u>
<u>Error Codes &amp; Troubleshooting</u>	<u>19</u>
<u>Cikada App Connection</u>	<u>22</u>
<u>Manufacturer's Limited Warranty</u>	<u>23</u>
<u>Distributor Contact Details</u>	<u>24</u>



**WELCOME TO THE CIKADA FAMILY AND CONGRATULATIONS ON PURCHASING YOUR NEW CIKADA E-BIKE.**

Thank you for your purchase of this quality product from CIKADA. Your new CIKADA bicycle is backed by one of the most comprehensive warranties available. CIKADA will do all we can to make your ownership experience as pleasant as possible for many years to come.

If you have any questions about your new EPAC contact the UK and or EU representative detailed below:

UK – Dyaco UK Ltd. 5 Mill Square, Featherstone Road, Wolverton Mill, Old Wolverton, Milton Keynes, Buckinghamshire. MK12 5ZD

Email: [support@cikadabikes.co.uk](mailto:support@cikadabikes.co.uk)



# PRODUCT **REGISTRATION**

**RECORD YOUR SERIAL NUMBER.**

Please record the Serial Number of this Cikada E-bike in the space provided below.

**Serial Number** \_\_\_\_\_

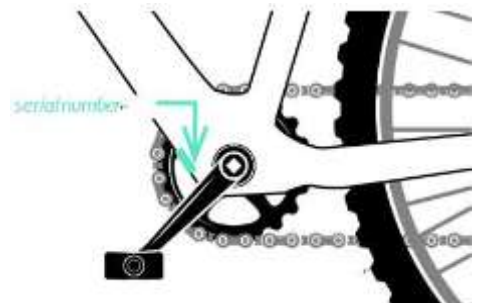

**REGISTER YOUR E-BIKE**

You can also go to <https://cikadabikes.co.uk> 'Cikada Care' under the support tab to register online, more details on page 22 & 23 below

# IMPORTANT SAFETY INSTRUCTIONS

## **Riding**

Please ensure your cycle complies with the Road Vehicle Lighting Regulations 1989 when riding on the public highway. Always use reflectors, front and rear lights that meets national and regional regulations during the hours of sunset to sunrise.

Always wear a helmet when riding.

Keep both hands on the grips on the handlebar and the brake levers within reach whilst riding to be able to immediately respond to any circumstances. Failure to do so may result in losing control of the bicycle.

- Do not exceed the maximum load of 330 lb. (150 kg) No more than one rider should be on the E-bike at a time. Maximum load includes rider's weight and total luggage weight.
- Child trailer and other bicycle trailer are not permitted for this Cikada E-bike.  
Notice: The A-weighted emission sound pressure level at riders ears is less than 70 dB(A).
- When riding in rain or snow, it will take longer to slow the cycle, so be aware of braking earlier than normal.
- Try to avoid riding in severe weather, such as heavy rain, snow, or wind.
- Do not use your cycle when under the influence of alcohol.
- For your personal safety, you must pay attention to the following safe use of electric bicycles:
- Before washing the EBike, you should read and understand the part of the manual about the "Precautions for washing".
- When adjusting the handlebars or saddles, care should be taken not to expose the safety marks of the handlebars and saddles.
- Always check your Cikada Bicycle before riding. If there are any issues found, please seek professional assistance with solving the issue or repair.
- Always check whether the front and rear brakes work normally.
- Always check that handlebars, front and rear wheels, and all other parts of the Cikada Bicycle are tightened properly: handle bar 19NM, stem binder 20NM, saddle 20NM, quick release axle 20NM. Common industry practice is resistance at lever half way through swing from open to fully close.
- Keep away from combustibles materials when charging, and do not leave the E-bike charging for an extended period of time.
- The battery should be used and maintained correctly in accordance with the method required by this manual. The battery should not be disassembled without authorisation and should be recycled by professional experts.
- The charger should be used and maintained correctly in accordance with the method required by this manual.

- Carefully read the warning labels and instructions of the charger before use. When replacing the charger, it should be purchased from Cikada only.

## **Precautions while riding:**

- Pay attention and observe all pedestrians, vehicles, obstacles, and others using the road at all times.

READ BEFORE RIDING.

- Do not drive under the influence of alcohol.

## **Clothing:**

- You should avoid clothes that may get tangled in the chain, or in a wheel or may obscure your lights when you are cycling.
- Light-coloured or fluorescent clothing can help other road users to see you in daylight and poor light, while reflective clothing and/or accessories (belt, arm or ankle bands) can increase your visibility in the dark.
- You should wear a cycle helmet that conforms to current regulations, is the correct size and securely fastened. Evidence suggests that a correctly fitted helmet will reduce your risk of sustaining a head injury in certain circumstances.

## **Riding At night**

Your cycle **MUST** have white front and red rear lights lit. It **MUST** also be fitted with a red rear reflector (and amber pedal reflectors, if manufactured after 1/10/85).

White front reflectors and spoke reflectors will also help you to be seen. Flashing lights are permitted but it is recommended that cyclists who are riding in areas without street lighting use a steady front lamp.

- Do not follow motor vehicles too closely (because they may slow down or turn at any time), and always pay attention to the brakes.
- Do not touch things on the road with your feet while riding.
- While riding at high speed, be sure to brake the bicycle slowly, and do not brake suddenly under any circumstances.
- When riding at night, slow down, ride with caution and use the lights of the vehicle.
- Try to ride in designated bicycle lanes or the edge of the road, in the direction of traffic flow.
- Stop at stop signs, slow down and watch traffic at intersections.
- Jackets, boots, trousers, gloves, etc. are effective protective clothing to prevent abrasions if an accident were to occur while riding. It is recommended to wear them to protect yourself.

- Please wear appropriate safety equipment according to the type of riding you plan to do. It is best to wear a pair of sports sunglasses, which can reduce the damage of ultraviolet rays to the eyes and protect the eyes from tree branches and flying rocks or stones.
- Please perform regular maintenance and inspection of your Cikada Bicycle. Refer to Cikada app for maintenance instruction.
- Please do not replace any parts by yourself to avoid damage.
- If any parts are damaged while riding that affect safety, please stop riding immediately.
- You should not listen to music while riding (because when you listen, it distracts your attention, and you cannot hear the sound of horns or other sounds of motor vehicles, which is very dangerous).
- If you have any problems while riding, please resolve the problem if possible or contact Cikada support for help.
- Avoid touching wheel rims, brake discs and brake callipers right after riding as they can be hot after usage.

## **Preparation for Riding**

- Pull the seat post out to the desired height. Follow the minimum insertion depth and minimum pull-out height specifications.
- If you can twist the saddle, the preload is too low. Correct the preload by tightening the adjustment screw.
- The front brake is operated by the right-hand brake lever.
- The rear brake is operated by the left-hand brake lever.
- Check the entire brake system for leaks, dirt and damage and carry out a stationary functionality test.
- Tire pressure is indicated on the sidewall of the tire. Use a pump with a pressure display when inflating the tires and always ride with the prescribed tire pressure.
- Check the front and rear rims at regular intervals for cracks, deformation or colour changes.
- The handlebars must be at a 90° angle to the front wheel. Have the handlebars adjusted by your dealer if they are not perpendicular to the front wheel.
- Gears are shifted up or down by pressing the relevant shift lever. Familiarise yourself with the gear shifting before your first ride. Stop if you cannot operate the gear shifting system safely, e.g. in the event of a malfunction.
- Make sure pedals are tightened to at least 35N.m

- When adjusting saddle height, make sure safety mark is not exposed. Raise or lower the saddle to a height that allows you to slightly touch the ground flat-footed while supporting your entire weight on the saddle. Make sure your legs are in a straight vertical position and your knees are NOT bent.
- The suspension fork should be properly adjusted according to your weight and terrain. Ensure the handlebar and handlebar stem are properly aligned, fitted to the user.
- Only use child seat if seat is suitable for your bike, have your child seat fit by your dealer or local bike shop. When fitting a child seat, have the saddle springs and all revolving/ moving parts completely covered to avoid injury. e.g. with a spoke protector.
- Luggage carrier is only permitted to be fitted on to designated area. Retrofitted luggage carrier is not permitted unless explicitly approved.
- If your model comes with luggage carrier, do not modify your luggage carrier. Maximum load limit is stamped on the surface of the luggage carrier.

## **Cleaning**

Precautions for washing the Cikada Bicycle:

- Turn off the E-bike before washing.
- Ensure the E-bike battery is locked in place.
- Do not wash your E-bike upside down.
- Do not use a strong stream or high-pressure water spray or jet washer.
- When washing the Cikada Bicycle, do not directly pour water on the motor and the front and rear axles to prevent water from affecting the performance and life of the product.
- After cleaning the E-bike or riding through water, pay special attention to the working conditions of the brakes. The braking capability may be reduced in wet road conditions.

## **Storage**

- Do not block access points to rooms, exits, evacuation stairs, emergency exits or walkways.
- Do not store your EBike in areas exposed to the elements.
- Do not store your EBike in areas where it may be subject to water ingress.
- Remove the battery when the bicycle is being stored.

## **Charging**

Do not charge or park the Cikada Bicycle in residential buildings.

Always place on a fireproof surface when charging.

- Keep away from combustibles when charging, and do not leave charging for over 8 hours.
- Do not charge the batter if you suspect it is damaged.
- Only use the original charger or Cikada genuine replacement charger.
- When charging, be sure to plug the charger to the battery end before plugging charger to the outlet.
- Red light shown on charger will remain lit while charging the battery. After charging is completed, red light will switch to green light.
- Do not leave the battery on charge unattended.
- Do not charge the battery close to room exits, emergency exits, stairwells, hallways or any other evacuation point.

## **Maintenance**

Always remove the battery when conducting any maintenance.

- Regularly clean the chain, chainring, sprockets, and care for the chain by regularly applying a suitable lubricant.
- Check the vehicle regularly for loose screw connections according to the maintenance schedule and tighten loose screws with a torque wrench. Do not ride the cycle if you find loose screw joints or have loose screw joints checked by your dealer if you lack the necessary expertise and the tools required.
- The optimum chain tension is achieved when you can push the chain up and down a minimum of 10 mm and a maximum of 15mm/0.4–0.6".
- To adjust the rear derailleur, shift the chain onto the smallest sprocket at the rear derailleur. Turn the H stop screw until the guide pulley is exactly underneath the smallest sprocket.
- Alterations to the cycle and incorrectly chosen spare parts can cause the cycle to malfunction. Consult your dealer about suitable spare parts or only use original spare parts.
- Only carry out maintenance yourself if you have the necessary expertise and the tools required. If you lack the necessary expertise and the tools required, have maintenance work carried out by your dealer.
- Have brake adjustments carried out by your dealer only.

Periodically based on use, inspect the frame, forks, suspension, joints and hinges for signs of excessive wear and or damage.

As with all mechanical components, E-bike is subjected to wear and high stresses. Different material and components may react to wear and stress fatigue in different ways. If the design life of a component has been exceeded, it may suddenly fail, possibly causing injuries to the rider. Any form of crack, scratches or change of colouring in highly stressed areas indicate that the life of the component has been reached and it should be replaced.

- Move the Cikada bicycle up, down, front, back, left and right to check whether the handlebars and the axle nuts of the front and rear wheels are tightened properly, whether the handlebars are tightened properly, and whether there is any abnormal rubbing or damage happening between parts.
- Push the vehicle back and forth to check whether the front and rear wheels rotate smoothly and without any abnormal noise or rubbing.
- Carefully check the entire bicycle before riding and if you find any issues, please contact a professional for repair or contact Cikada support for help.

## **Inspection of power circuit and lighting circuit**

- Turn on the power, operate the lighting switch, check whether the headlights and rear lights are on, and if they are at normal levels.
- Check for any damage with the lighting system.
- Check whether the power cables on the Cikada Bicycle are connected and are operating safely as intended as well as whether all connectors are functioning properly.
- Inspection of front and rear brakes.
- Adjustment of the brake lever: Pinch the front and rear brake levers and confirm whether the brakes are working when the distance between the brake lever and the handlebar is 1 inch.
- Adjustment method of the front and rear brakes: The distance between the grip and the brake lever is specified to be between 10-20mm.
- When the brake is fully applied and on, the brake pad and the brake disc should be contacting evenly.
- The brake pads and brake discs should be replaced at the same time (the adjustment of the rear wheel brake is the same as that of the front wheel brake).
- Battery installation status.
- Confirm that the battery is in a fixed state, connected, and operating properly.

## **Safety Critical Components**

- Following are critical safety components. Front fork, handlebar, stem, seat post, brake lever, brake blocks and holder, cable casing, brake tubing, brake callipers, brake discs, brake pads, chain, pedals and cranks. Always check these parts before riding.

## **Tampering**

- Do not modify your bicycle in any way that may change its original design. Do not tamper with your bicycle.
- Tampering will void your warranty and introduce potential safety issues.

# Rechargeable battery safety instructions

- Damage to the rechargeable battery can cause fires and explosions. Do not attempt to put out the rechargeable battery fire by yourself. Keep back from the rechargeable battery and let it burn out in a controlled way.
- Internal damage to the rechargeable battery may cause overheating or result in liquid and/or gas leaking from the battery. Have the rechargeable battery checked by a dealer after hard bike falls or impacts. Do not open, dismantle, pierce, or deform the rechargeable battery and battery housing.
- Do not charge the battery if you suspect it may be damaged.
- Do not use the rechargeable battery if you notice any unusual heat or discoloration.
- Only charge the battery with the original charger, and do not leave it unattended while charging.
- Always place the rechargeable battery on a fireproof mat.
- Only touch possible damaged rechargeable batteries with protective gloves. Wear safety goggles and an apron when in contact with a possibly damaged rechargeable battery. Dispose of it in accordance with the requirements of your area.

## Product Specification

Battery	LG21700 720Wh	Charger	54V
Range	120 miles	Controller	48V5A
Electric bike class	Class 1	Display	LCD W/ BLE
Motor	250W	Frame	Aluminium 6061
Charging time	6 hours	Pedal Assist	Lvl 1-5
Total payload capacity	330 lbs / 150 kg	Top speed	15 Mph (25 km/hr)
Recommended rider's height	5'2~5'8 (M) 5'5~6'4 (L)	Net weight	59.5 lb/27 kg
Tire pressure	40-65 PSI		

# Bike assembly

- Assembly Preparation

Pedals\*2

#4 Allen Wrench\*1  
#5 Allen Wrench\*1

15mm Open Wrench\*1

Battery\*1

Battery Charger\*1

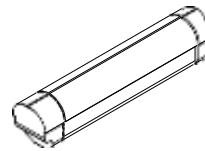
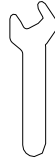
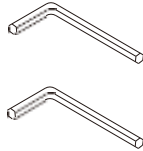

- Loosen the two socket cap screws located behind the stem. Adjust handlebar to the correct position. Make sure the front wheel is correctly facing forward as well.

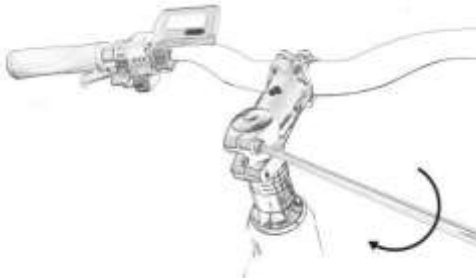

Use a 4 mm Allen wrench to loosen the four socket cap screws at the front of the stem. Adjust handlebar to the correct position. Make sure the front wheel is correctly facing forward as well.

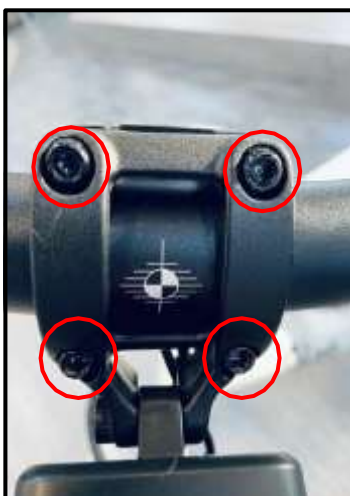

- **Install the pedals.**

Use the 15mm open wrench to install the pedals. Pay attention to which pedal is being installed on the left and the right as the left pedal is reverse-threaded, so it is tightened counterclockwise.

### Right Pedal Installation

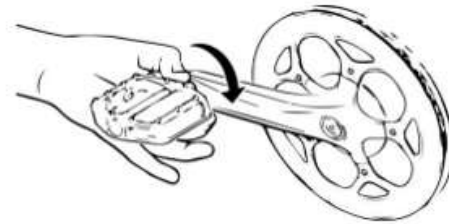
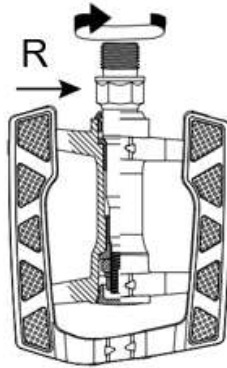
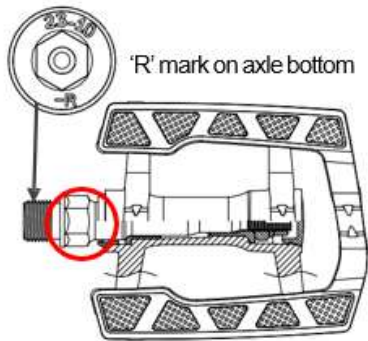

### Left Pedal Installation

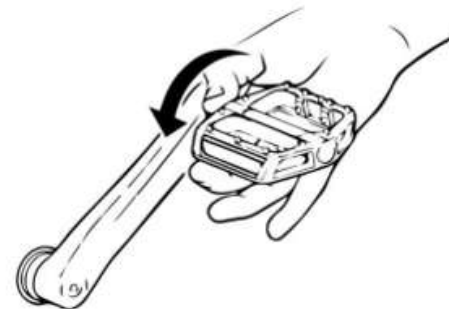
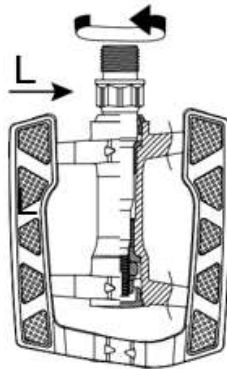
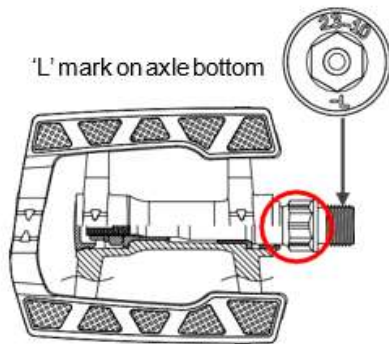

- **Adjust the height of your saddle**

The saddle height can be adjusted via the quick release on the frame under the saddle

Set your seat height so that there is a slight bend in your knee when your foot is on the pedal at its lowest position while sitting on the saddle.

# Control instructions

Default Passcode: 0000



1. Remaining Battery
2. Assist level/ Walk Assist
3. Headlight Symbol
4. Bluetooth Icon
5. Speed Unit
6. Real Time Speed
7. Trip Information

## Switching system On/Off

Press and hold the Power button to turn on the system. Press and hold the Power button again to turn off the system. The "Automatic Shutdown Timer" is set to 5 minutes; the display will turn off automatically in 5 minutes when the E-bike is not in operation. If the password function is enabled, you must enter the correct password to power on the system.

## Select Assist Levels

When the display is turned on, press + or – to switch to the desired Assist Level. The lowest level is 0, the highest level is 5. When the system is powered on, pedal assist starts at level 1. There is no pedal assist at level 0.

Level 0: OFF

Level 1 Eco: Efficient and optimised assistance for maximum autonomy. 35% Max motor power.

Level 2 Cruise: Providing constant assistance over long distances. 50% Max motor power.

Level 3 Sport: Powerful constant assistance. 65%Max motor power.

Level 4 Hill: Suitable for accelerating. 90%Max motor power.

Level 5 Turbo: Provides powerful assistance when going uphill. 100% Motor power.



## Trip Information

Press the Power Button to see different trip information including: Daily kilometres/miles, Total kilometres/miles, Maximum Speed, Average Speed, Remaining Distance, Calorie Consumption, Power Output, and Time Travelled.

## Headlight

Hold the + button to activate headlight, hold the + button to turn off headlight.

## Walk Assist

Press the – button until  appears. Now hold the – button to engage walk assist. The symbol  will blink and your Cikada ebike will move forward at approx. 4.5 km/h. After releasing the - button or no button is pressed within 5S, the motor stops automatically and switches back to level 0.







## Service

The display shows "SERVICE" as soon as mileage of more than 5000 km (or 250 charge cycles) has been reached.. This function can be set in the display settings.



## Battery Indicator

The Remaining battery is shown in the top left of the display. Each full bar represents remaining battery in percentage points.

Capacity Range	Indicator
80%-100%	
60%-80%	
40%-60%	
20%-40%	
5%-20%	
< 5%	 blinking

## **Charging**

A red light shown on the charger will remain lit while the battery is still charging. After the charging is complete, the red light will switch to a green light.

## **Settings**

After the display is turned on, press and hold the + and - buttons to enter the Settings menu, by pressing the + or – button, you can highlight or select Display Settings, Information or Exit. Press the Power Button to make your selection.

Display Settings includes: Trip Rest, Unit Selection, Screen Brightness, Automatic System Off Timer, Service Timer.

“Information” includes: Wheel Size, Speed Limit (fixed), Battery Information, Controller Information, Console Information, Torque Sensor Information (depending on bike models), and Error Code.

# Anatomy of your E-Bike

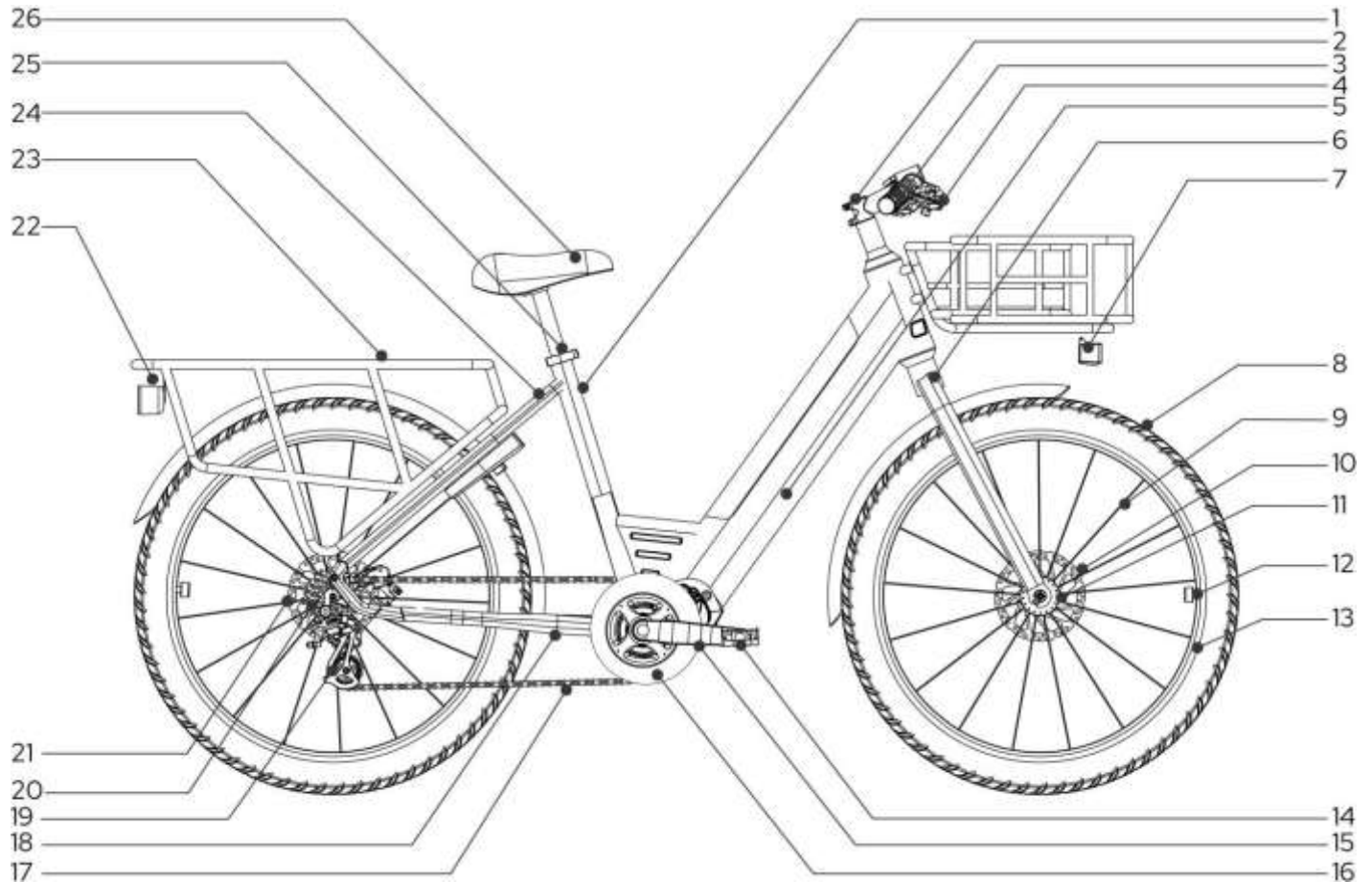

1	Seat tube	14	Pedal
2	Handlebar stem	15	Crank
3	Handlebar	16	Chain ring
4	Brake lever	17	Chain
5	Down tube	18	Chain stay
6	Front fork / suspension fork	19	Rear derailleurs
7	Headlamp	20	Cassette
8	Tire	21	Rear brake
9	Spoke	22	Rear lamp/ Reflector
10	Front brake	23	Luggage carrier
11	Wheel hub	24	Seat stay
12	Valve	25	Seat post clamp
13	Rim	26	Saddle

# Error messages

Error	Description	Troubleshooting
07	Overvoltage Protection	<ol style="list-style-type: none"> <li>1. Remove and re-insert the battery to test whether it resolves the error message.</li> <li>2. Using the BESST tool update the controller.</li> <li>3. Replace the battery with a new one to resolve the problem.</li> </ol>
08	Faulty torque/hall sensor signal inside motor	<ol style="list-style-type: none"> <li>1. Ensure that all connectors from the motor are correctly connected.</li> <li>2. If the problem persists, please change the motor unit.</li> </ol>
09	Motor Malfunction	Please contact your dealer.
10	Motor Overheat Protection	<ol style="list-style-type: none"> <li>1. Turn off the System and allow the motor to cool down.</li> <li>2. If problem persists, please contact your dealer.</li> </ol>
11	Motor Temperature Sensor Error	Please contact your dealer
12	Controller Sensor Error	Please contact your dealer
13	Battery Temperature Sensor Error	Please contact your dealer
14	Controller Overheat Protection	<ol style="list-style-type: none"> <li>1. Turn off the system and allow controller to cool down.</li> <li>2. If the problem persists, please contact your dealer.</li> </ol>
15	Controller Temperature Sensor Error	<ol style="list-style-type: none"> <li>1. Turn off the system and allow the controller to cool down.</li> <li>2. If the problem persists,</li> <li>3. please contact your dealer.</li> </ol>

21	Speed Sensor Error	<ol style="list-style-type: none"> <li>1. Restart the system.</li> <li>2. Check if the magnet attached to the spoke is aligned with the speed sensor and that the distance is between 0.4 and 0.8 inches.</li> <li>3. Ensure that the speed sensor connector is connected correctly.</li> <li>4. Please contact your dealer if error persists.</li> </ol>
25	Torque Signal Error	<ol style="list-style-type: none"> <li>1. Ensure all connections are connected correctly.</li> <li>2. Please contact your dealer if problem persists.</li> </ol>
26	Speed Signal in Torque Sensor Error	<ol style="list-style-type: none"> <li>1. Ensure all connections are connected correctly.</li> <li>2. Please contact your dealer if problem persists.</li> </ol>
27	Controller Overcurrent	Please contact your dealer
30	Communication Error	<ol style="list-style-type: none"> <li>1. Ensure all connections are connected correctly.</li> <li>2. Please contact your dealer if problem persists.</li> </ol>
33	Brake signal error	<ol style="list-style-type: none"> <li>1. Ensure all connections are connected correctly.</li> <li>2. Please contact your dealer if problem persists.</li> </ol>
35	15V Detection Circuit Error	Please contact your dealer
36	Keypad Detection Circuit Error	Please contact your dealer
37	WDT Circuit Error	Please contact your dealer
41	Total Voltage too High	Please contact your dealer
42	Total Voltage too Low	Please contact your dealer
43	Total Battery Power too High	Please contact your dealer
44	Single Cell Battery High Voltage	Please contact your dealer
45	High Battery Temperature	<ol style="list-style-type: none"> <li>1. Turn off the system and allow the battery to cool down.</li> </ol> <p>If problem persists, please contact your dealer.</p>

46	Low Battery Temperature	<ol style="list-style-type: none"> <li>1. Bring battery to room temperature.</li> <li>2. Please contact your dealer if problem persists.</li> </ol>
47	Battery SOC too High	Please contact your dealer
48	Battery SOC too Low	Please contact your dealer
71	Electronic Lock Error	Please contact your dealer
81	Bluetooth Module Error	Please contact your dealer

# Cikada App Connection



## Getting Started with the Cikada App



### Guidelines to connect your E-bike to the Cikada App.

- 1) Download the Cikada App from the App Store on your smartphone.
- 2) Turn on your E-bike display.
- 3) Ensure Bluetooth is enabled on your smartphone and grant the Cikada App Bluetooth access.
- 4) Open the Cikada App and allow it to access Bluetooth.
- 5) Tap "Register" on the home screen to sign up using email, Facebook, Apple ID or Google.
- 6) Follow the instructions, then tap 'Pair Now' or press the E-bike's 'Up and Down button' to display the QR code for scanning.
- 7) After successful pairing, you'll be prompted to enter a set of Passcodes (4 codes) as the unlocking password.
- 8) Once pairing and binding are complete, the phone will automatically connect to the E-bike when nearby, without needing to enter a passcode.



# Manufacturer's Limited Warranty

## Warranty Info:

Cikada provides a Limited Warranty for parts listed below.:

Frame: 2 years (If registered via the download Cikada APP or thru <https://cikadacare.com/bikeRegister> entering the register user, serial number and activate the warranty, an additional 3 years limited warranty will be added to the existing 2 years limited warranty – extending to 5 years in total)

Fork: 2 years

Electronics (Does not include battery): 2 years

Battery: Up to 600 times recharges / 2 years

Accessories: 1 year

All other non-wearing components: 2 years

Labour – Cikada does not offer labour for warranty service.

Please see Cikada website for more information.

This Limited Warranty is only applicable to the product purchases and in accordance with the following terms:

- This Limited Warranty shall only apply based on purchases made directly from cikadabikes.com or through Cikada authorised resellers. Owners must be able to provide proof of purchase in order or have completed the warranty registration with Cikada for the warranty to apply.
- Only the first registration from the original owner of the Cikada product is covered by this Limited Warranty. The Warranty Period begins upon your receipt of the Product and shall end according to the limited warranty period.

## **This Limited Warranty Does Not Cover:**

- Consumables or normal wear and tear on parts such as tires, rims, spokes, wheel hubs, chains, brakes, cables, grips, headsets, and pedals in situations where there are no assembly or material defects.
- Any damage or defects to covered components resulting from failure to follow instructions in the product owner's manual, misuse, personal modification, improper assembly, improper installation, operator fault, water or sweat corrosion, unsanctioned riding, stunt riding, or improper maintenance.
- Any unauthorised service or use of unauthorised parts are not covered by this Limited Warranty.
- Power surges, improper charger, improper maintenance or other such misuse, normal wear, or sweat or water damage may damage the battery. The battery is guaranteed to last around 600 times recharges within the two-year period from purchase.

# Reach Out To The Distributor

- **Service Email Addresses**

<b>Location</b>	<b>Email Address</b>
UK	<a href="mailto:support@cikadabikes.co.uk">support@cikadabikes.co.uk</a>

- **Addresses: Cikada Products**

**Dyaco UK Ltd**

Unit 5 Mill Square, Featherstone Road, Milton Keynes, MK12 5ZD

<https://cikadabikes.co.uk>

[support@cikadabikes.co.uk](mailto:support@cikadabikes.co.uk)