

YORK[®] FITNESS

Owner's Manual

530 Bench

45069

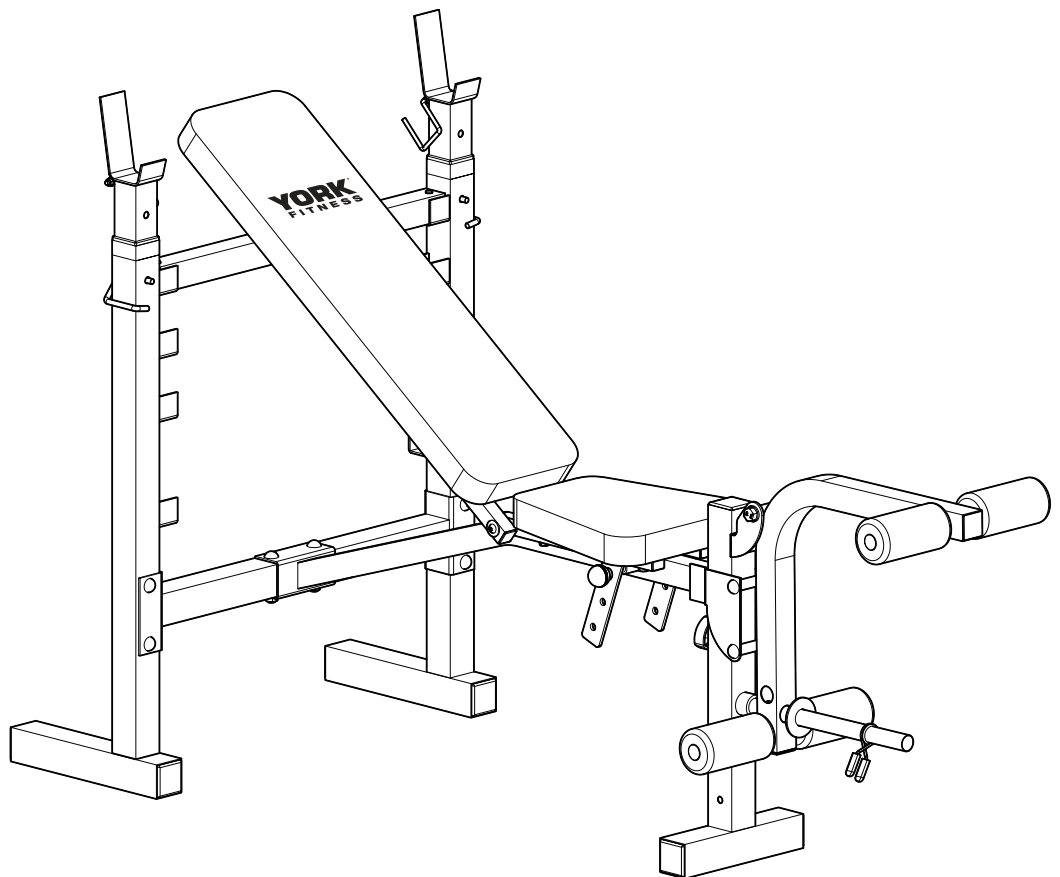

V1.3 15NOV2013

Table of contents

Congratulations on purchasing your exercise equipment from



You have chosen a high quality, safe and innovative piece of equipment as your training partner and we are certain it will keep you motivated on the way to achieving your personal fitness goals.

Please take the time to read this owner's manual as it will help you to get the most out of your new exercise equipment.

For more information visit www.yorkfitness.com

CONTENTS

Safety information	03
Customer support	04
Assembly instructions	05
Fitness guide	10
Exploded drawing	11
Part list	11

Safety information

Please read this instruction manual before you begin assembly. Great care has been taken to design these instructions and following them will help you with quicker assembly and minimize the risk of injury.

It is important that you keep these instructions for future reference.

This list is not exhaustive - You are responsible for your own safety!

- Assemble the product on a level surface
- You will need at least one person to help you assemble this unit.
- Always use the product on a level surface, ensure that the product is stable before use.
- Always ensure that the equipment has adequate space on each side and front (the back can be near to a wall).
- Replace defective components immediately, and/or keep the equipment out of use until it is repaired.
- Use only the adjustment settings as described in the instructions. Always use the correct adjustment pin and/or locking devices.
- Always check that any pins / fixings are tight and secure before use and / or after adjustment.
- Never leave any adjustment devices projecting from the product.
- Always consult your doctor before undertaking any exercise program.
- Always wear suitable clothing and footwear e.g. tracksuit / shorts / training shoes
- Remove all personal jewelry before exercising.
- Ensure you warm-up well before using the equipment as this will help to prevent muscle strain.
- After eating, allow 1-2 hours before exercising as this will help to prevent muscle strain.
- Injuries to health may result from incorrect or excessive training.
- Never overload the equipment - the maximum user load is displayed in these instructions and on the product label.
- We recommend that you do not lift weights alone. There should be somebody there to assist you.
- Never use the equipment in any other manner other than the ways explained in these instructions and/or any wall-chart supplied.

- Parents and others in charge of children should be aware of their responsibility, because the natural play instinct and the fondness of experimenting of children can lead to situations and behavior for which the training equipment is not intended
- If children are allowed to use the equipment, their mental and physical development and above all their temperament should be taken into account. They should be controlled and instructed in the correct use of the equipment.
- The equipment is under no circumstances suitable as a children's toy.
- Children should not be allowed on, or around the equipment - especially when it is not in use.
- This product has been tested for use in a home environment and is warranted for In Home, personal, family or household use.
- Due to our continuous policy of product development, York Fitness reserves the right to change specifications without notice.

CAUTION! The instructions must be followed carefully in the assembly, use and maintenance of your equipment. The warranty does not cover damage due to negligence of the assembly, adjustment and maintenance instructions described herein.

**100kg User Weight
100kg Training Weight**

Safety Standards

This bench meets the requirements of British and EU safety standards EN957 parts 1 and 4, Class HC.

Tools and consumables

- 1 x 13 - 17mm double ended spanner
- Pliers should not be used!

This product is not suitable for therapeutic purposes.

Customer support

Customer Support

Should you require any assistance regarding this product please gather the following information and then contact us using the details below:

- Serial No. - This can be found on the sticker below, located as indicated.
- Original purchase date
- Place of purchase
- Information about the place and conditions of use
- Precise description of the issue / defect

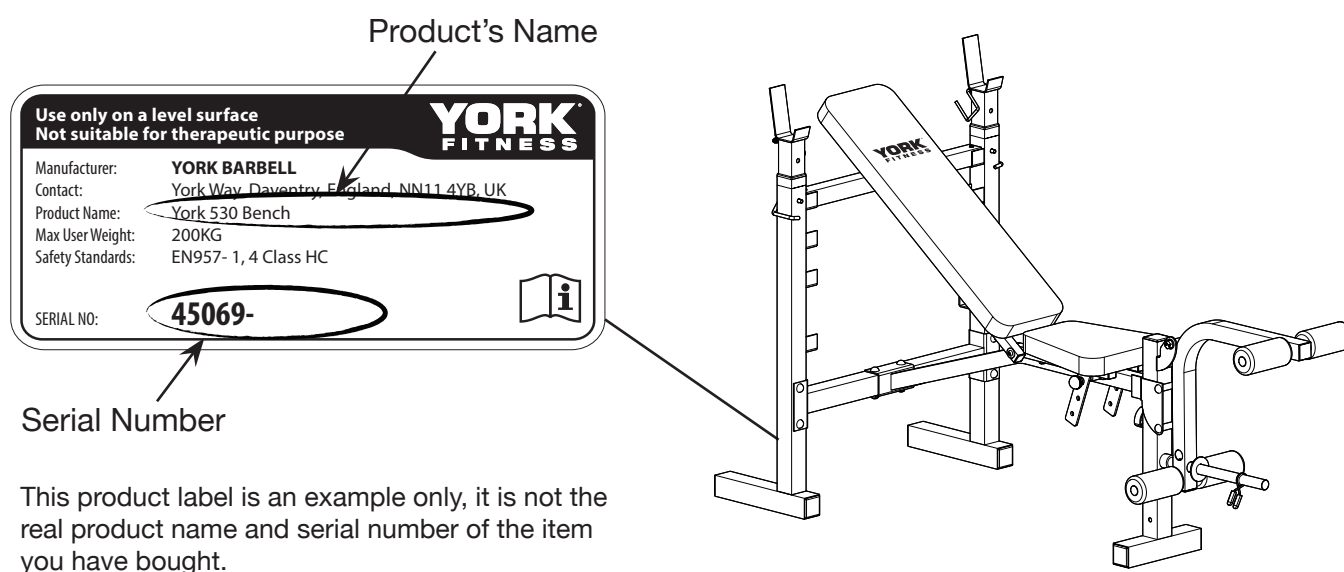

This product label is an example only, it is not the real product name and serial number of the item you have bought.

IMPORTANT!! - Please retain your sales receipt, York Fitness Customer Care may request proof of purchase to validate eligibility for warranty service. Warranty cover starts from the date shown on the proof of purchase.

ENGLAND - York Barbell UK Ltd.

York Way, Daventry,
England, NN11 4YB
Tel: 0844 225 3112
Website: www.yorkfitness.com

AUSTRALIA - York Fitness Australia

1/2 Swaffham Rd, Minto,
PO Box 5130, NSW 2566
Tel: 1800 730 149
Website: www.yorkfitness.com.au

USA - York Barbell USA Inc.

3300 Board Road,
York, PA 17406
Tel: 1 (717) 767-6481
Toll Free: 1 (800) 358-9675
Website: www.yorkbarbell.com

Canada - York Barbell Co. Ltd. Canada

1450 South Service Rd. West,
Oakville (Toronto), ON, L6L 5T7
Tel: 1 (905) 827-6362
Toll Free: 1 (800) 361-0448

Assembly instructions

Care & Maintenance

- We recommend placing a mat beneath the equipment to protect both the equipment and your flooring
- Always place the equipment in a dry environment.
- Use a warm, damp cloth to keep the product clean.
- The safety level of the equipment can be maintained only if it is regularly examined for damage and wear at the start of every use. This includes any nuts, bolts, moving parts, bushes etc.
- Ensure that all fixings are tight before use.
- Always replace damaged / worn components with original parts from the manufacturer.

Prepare your work area - It is important you assemble the product in a clean and uncluttered space.

Work with a friend - We recommend you have someone assist you with the assembly as some of the components are quite heavy.

Unpack the carton - Remove all the parts and lay them out on the floor.

Check to make sure you have all part, nuts, bolts... etc, before you start assembly. If you are missing any parts and the box was un-opened when you left the store, please contact York Customer Service.

Blister Pack:

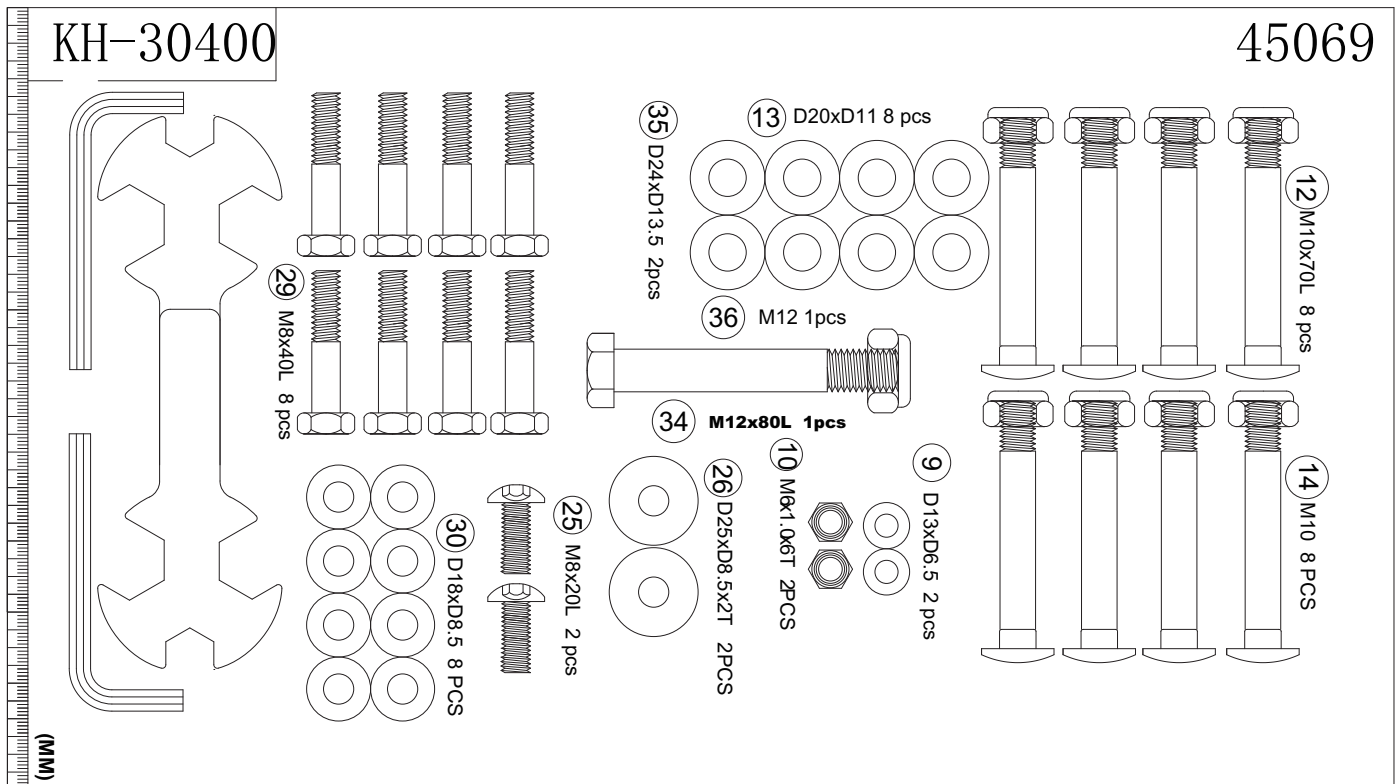

Assembly instructions

1

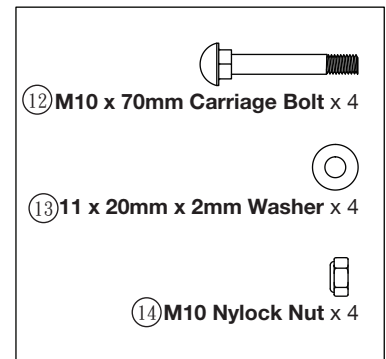
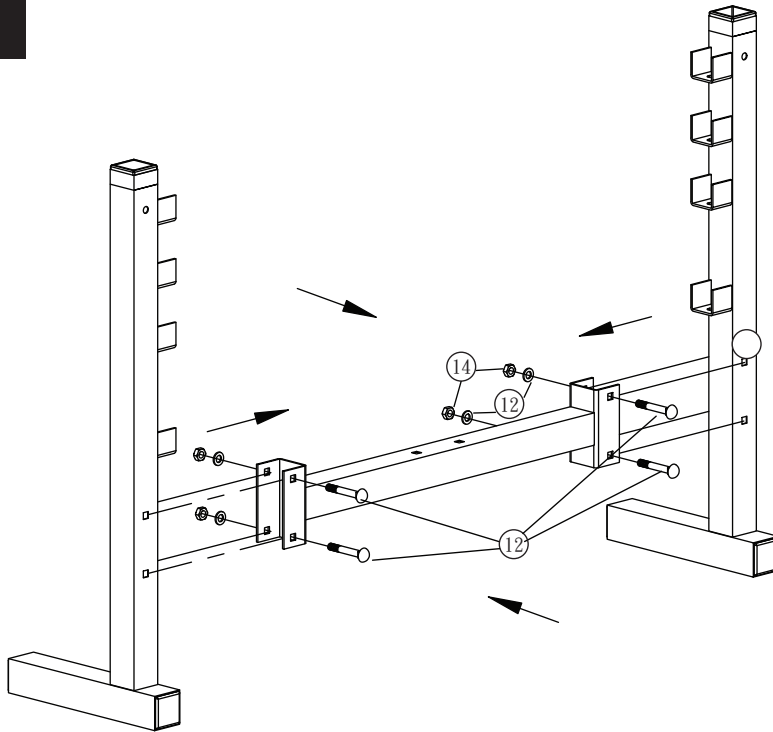

2

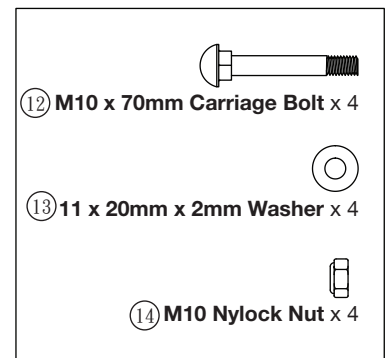
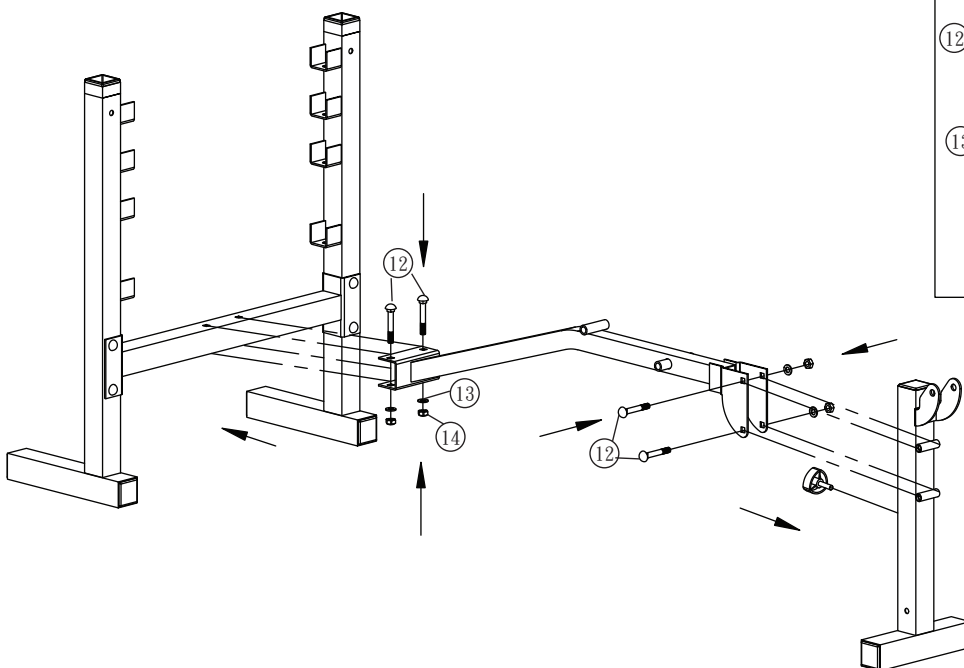

3

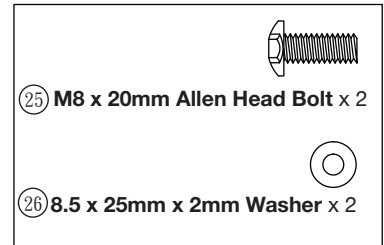
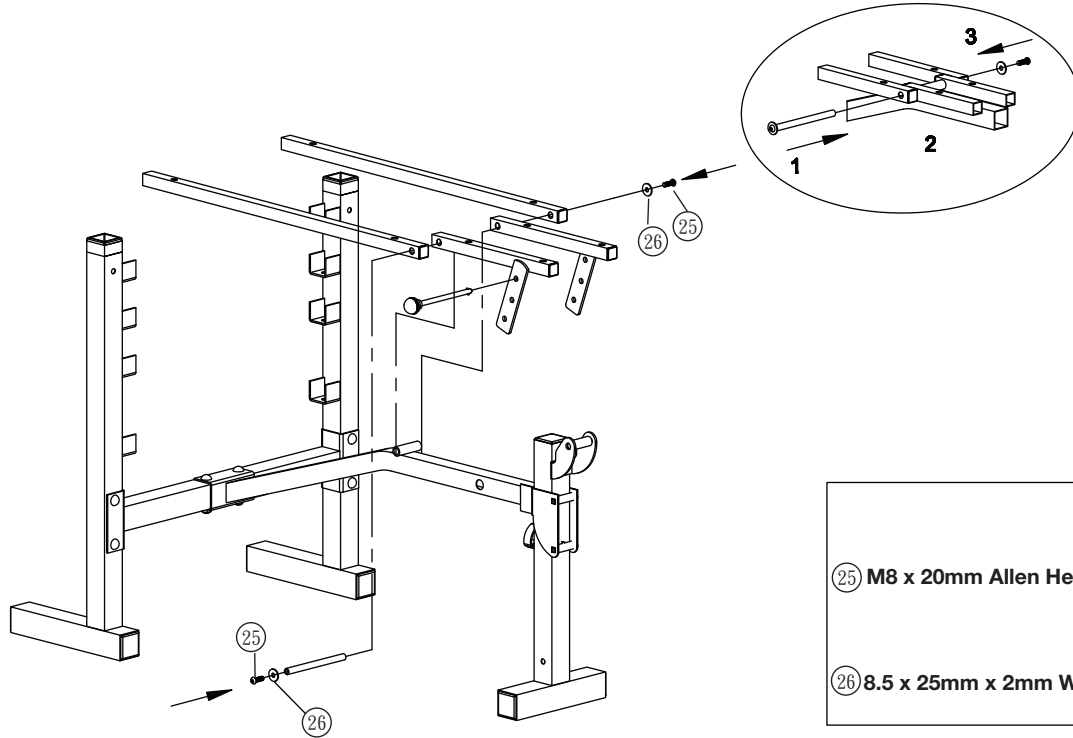

4

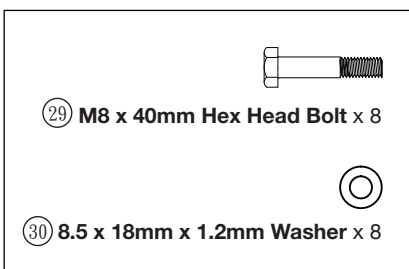
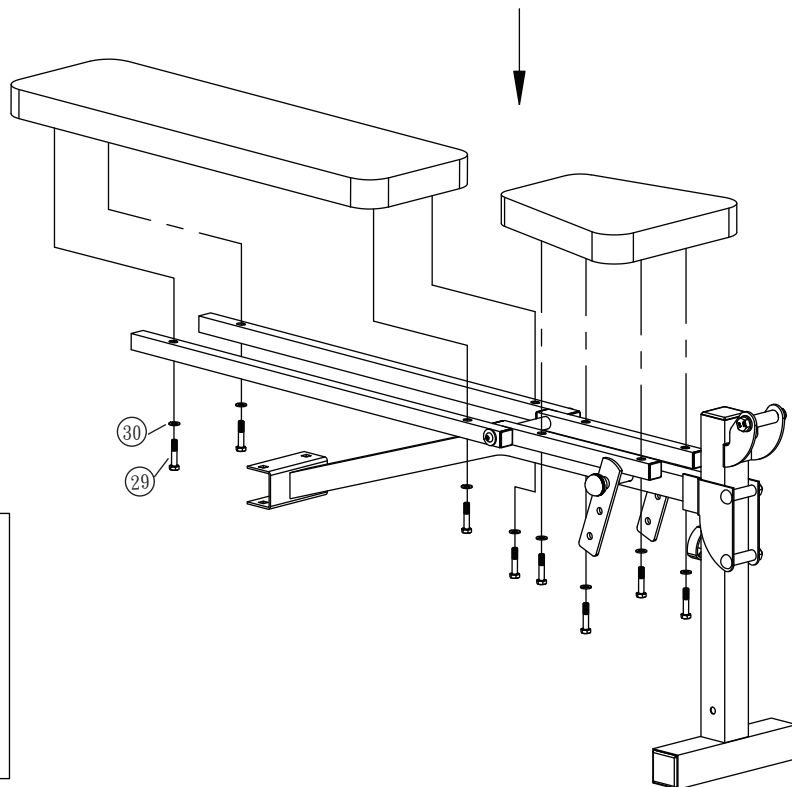

Assembly instructions

5

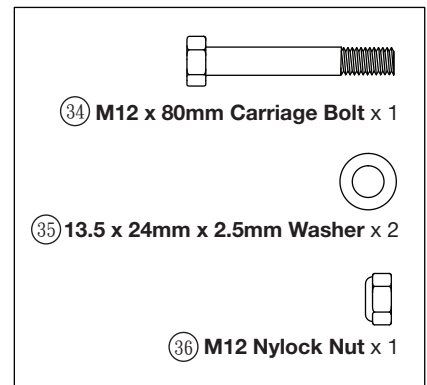
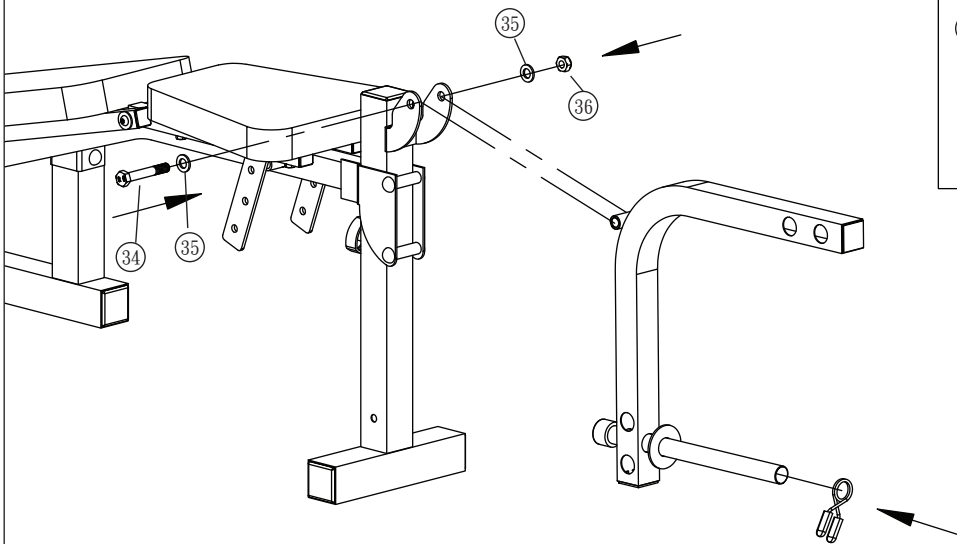

6

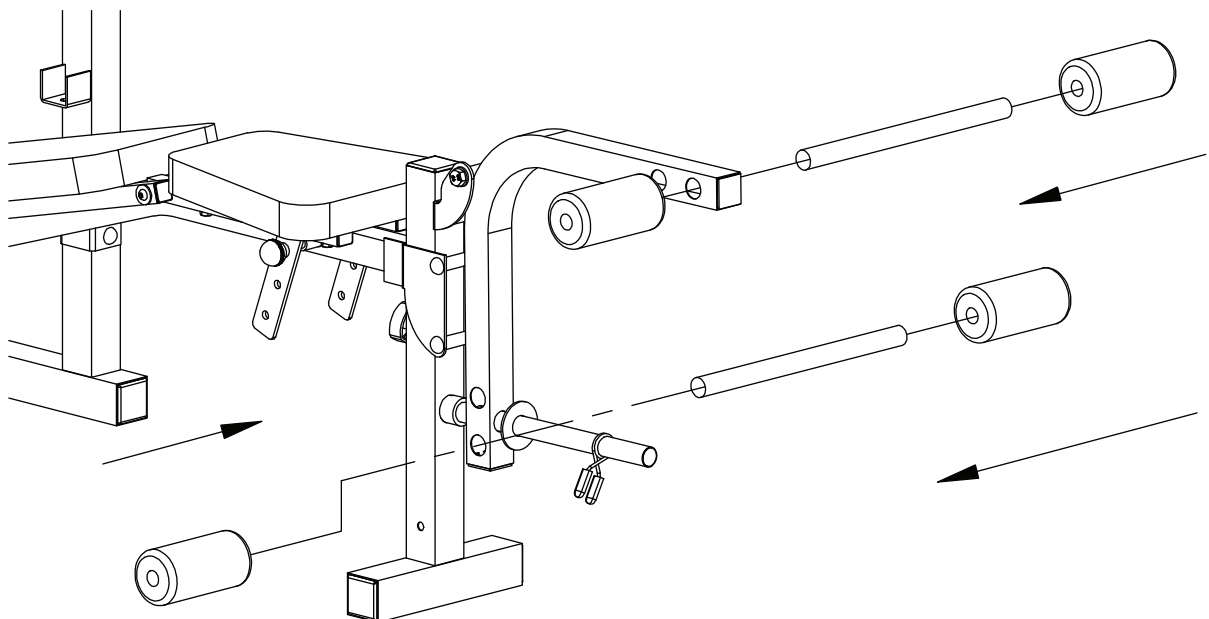

7

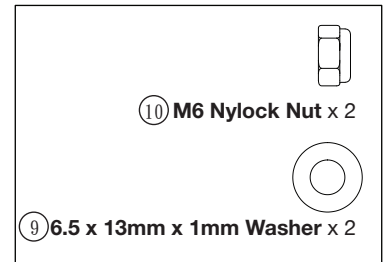
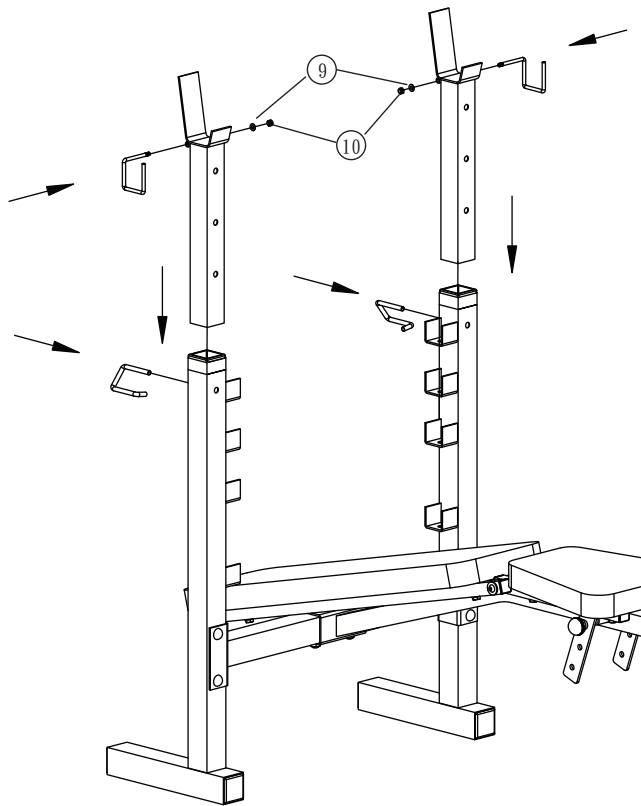

8

Please make sure this back rest adj. bar is located in the top bracket before you secure the bolts, washers and locknuts.

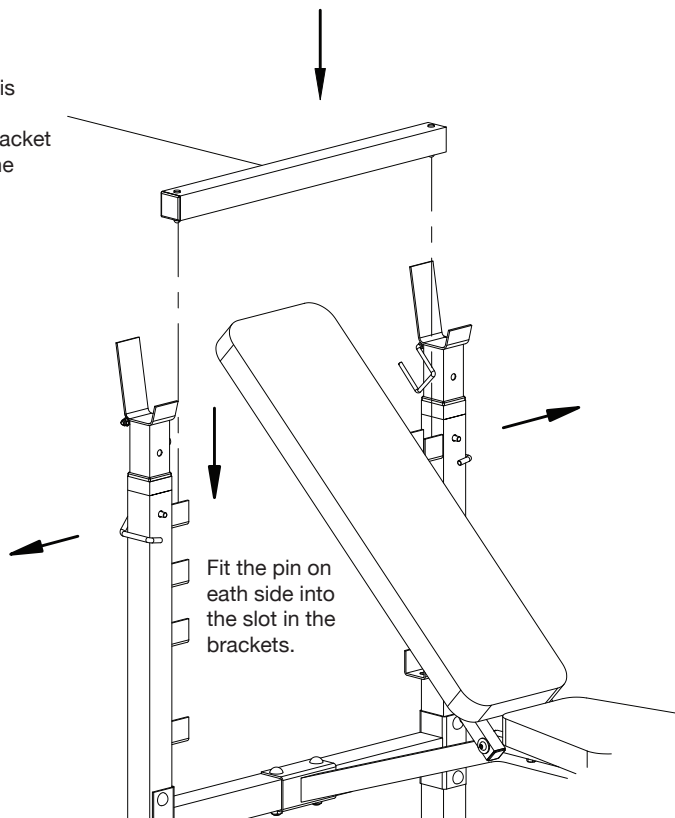

Fit the pin on each side into the slot in the brackets.

Fitness guide

Starting Your Workout

Begin each workout with a Warm Up session - a few minutes of stretching to help prevent strains, pulls and cramps.

1. Perform some gentle stretching
2. Do light cardiovascular exercise (i.e. cycle) for approx 5-10 mins
3. 'Dry-run' one exercise per body part without using weights to ensure muscles and joints are warm

Finishing Your Workout

End each work-out with a warm down session – the purpose of this is to lower your heart rate slightly and to prevent strains, pulls and cramps.

1. Perform 3-5 minutes of light cardiovascular work to gradually lower heart rate and reduce body temperature back towards resting levels
2. Exercise should be rhythmical and of gradually decreasing intensity.
3. Stretch all the major muscle groups – this will aid recovery and return the muscles to their normal length

Correct Exercising Form

- Hold weights with a comfortable grip (avoid gripping too tightly)
- Stand, sit or lie as described below, paying particular attention to your abdominal muscles which help support your back:
- Standing - For most standing exercises use a split foot position (feet apart with one foot forward hips remain square to front), stand tall and pull abdominals firmly in
- Seated – Feet parallel, hip width apart, sit tall and pull abdominals tightly in
- Lying down – Always ensure back to bench and abdominals tightly pulled in
- Ensure joints remain soft (not locked out) and movements are carried out in a smooth and continuous way. (Each repetition should take you approximately a slow count of 4 to do)
- Avoid using 'momentum' and instead focus on the muscles you are working - throwing weights with poor technique increases the risk of injury and reduces training benefits
- Use full range of movement for each repetition performed
- Do not hold breath whilst training, instead exhale on the hardest phase of the exercise and inhale on the easier phase e.g.) Bicep Curl – exhale as you curl dumbbell towards shoulder and inhale as you return the weight to the start position

Choosing Your Weights

Start with a weight you can perform 12 repetitions without crossing the line from 'challenged' to 'struggle'. If you cannot maintain correct technique, the weight is too heavy!

Gradually increase the weight as you become stronger and more practiced.

Training for increased muscle size

- Keep your sets between 8 – 12 repetitions
- Repeat each individual exercise 2 or 3 times increasing weight slightly and decreasing repetitions i.e.. 1st set 12 repetitions, 2nd set 10 repetitions, 3rd set 8 repetitions
- Rest for 1 minute between sets

Training for shape/definition

- Sets should be 12 – 15 repetitions
- Repeat each individual exercise 1 or 2 times with sets of between 12 - 15 repetitions
- Rest for 1 minute between sets

Please see the accompanying wall chart for guidelines on how to perform specific exercises...

Exploded drawing / Part List

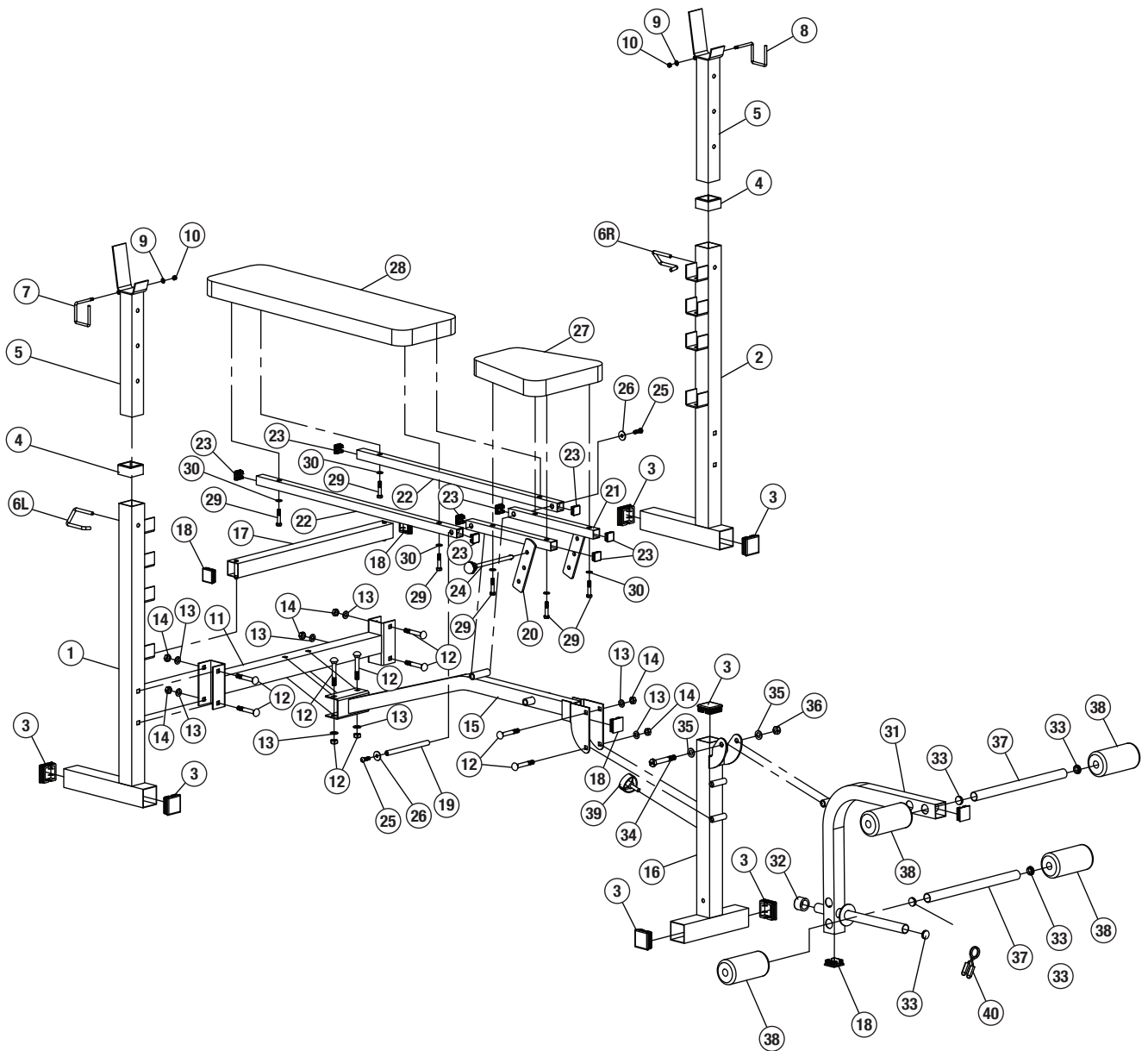

YORK REF.	REF.	DESCRIPTION	QTY.
45069-001	1	LEFT UPRIGHT	1
45069-002	2	RIGHT UPRIGHT	1
45069-003	3	END CAP SQUARE (50*50*18.5)	7
45069-004	4	HOLLOW CAP (55*55*45*45*36L)	2
45069-005	5	ADJUSTABLE BAR RACK	2
45069-006	6L	LOCK PIN LEFT (D8*72*40)	1
45069-007	6R	LOCK PIN RIGHT (D8*72*40)	1
45069-008	7	LOCK PIN LEFT (D6*60*70)	1
45069-009	8	LOCK PIN RIGHT (D6*60*70)	1
45069-010	9	FLAT WASHER (D13*D6.5*1T)	2
45069-011	10	NYLON WASHER (M6*1.0*6T)	2
45069-012	11	CROSS BAR SUPPORT	1
45069-013	12	SQUARE NECK BOLT (M10*1.5*70L)	8
45069-014	13	FLAT WASHER (D20*D11*2T)	8
45069-015	14	NYLON WASHER (M10*1.5*10T)	8
45069-016	15	MAIN FRAME SUPPORT	1
45069-017	16	FRONT SUPPORT	1
45069-018	17	BACK REST ADJUSTABLE BAR	1
45069-019	18	END CAP SQUARE (38X38X15)	5
45069-020	19	PIVOT SHAFT (D12.7*161.5L)	1
45069-021	20	SEAT SUPPORTING TUBE LEFT	1

YORK REF.	REF.	DESCRIPTION	QTY.
45069-022	21	RIGHT SUPPORTING TUBE RIGHT	1
45069-023	22	BACK REST SUPPORT (25*25X1.5TX778L)	2
45069-024	23	END CAP SQUARE (25*25*15)	8
45069-025	24	SELECTING PIN	1
45069-026	25	ALLEN BOLT (M8*1.25*20L,8.8)	2
45069-027	26	FLAT WASHER (D25XD8.5X2T)	2
45069-028	27	SEAT UPHOLSTERY (305*300*40)	1
45069-029	28	BENCH UPHOLSTERY (780*230*40)	1
45069-030	29	HEX BOLT (M8*1.25*40L)	8
45069-031	30	FLAT WASHER (D18XD8.5X1.2T)	8
45069-032	31	LEG DEVELOP SUPPORT	1
45069-033	32	BUFFER (D35*D25.5*24)	1
45069-034	33	END CAP ROUND (D1"*X17.5L)	5
45069-035	34	HEX BOLT (M12*1.75*80L)	1
45069-036	35	FLAT WASHER (D24*D13.5*2.5T)	2
45069-037	36	NYLON NUT (M12*1.75*12T)	1
45069-038	37	LEG FOAM TUBE (D25.4X1.4T*350L)	2
45069-039	38	FOAM (D23*D90*155L, REACH, PAHS)	4
45069-040	39	FIXING KNOB (M12*1.75*40L)	1
45069-041	40	PINCHCOCK (D1"*90)	1



YORK[®]
FITNESS

www.yorkfitness.com