

VIAVITO[®]

Owner's Manual.

Flat Weight Bench

www.viavito.com

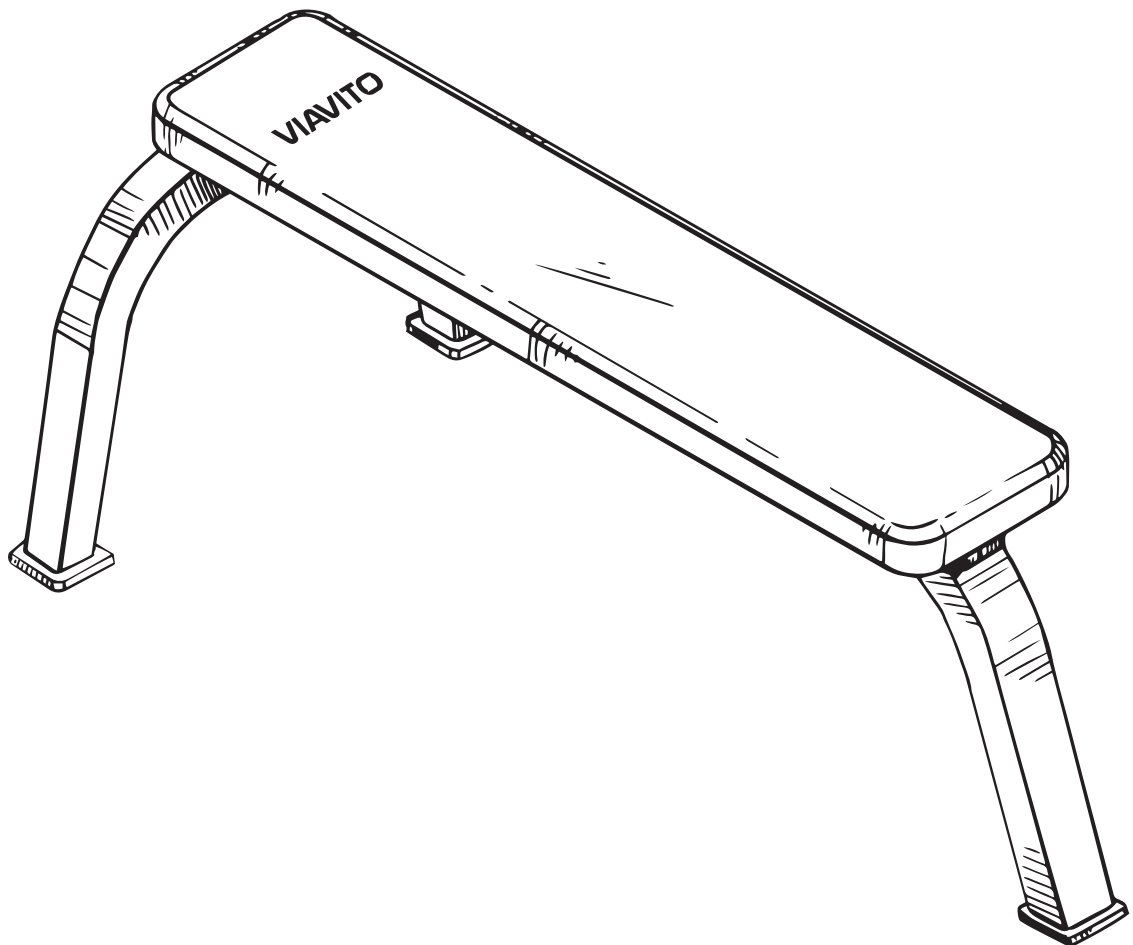

Manual version 1.2



Congratulations on purchasing your very own Viavito **Flat Bench**

You have chosen a high-quality, safe and innovative product, and we are certain it will help you achieve the results you want.

Please take the time to read this owner's manual as it will help you to get the most out of your new product.

For more information, or if you require any assistance please email us at **support@viavito.com**

Safety Standards

The weight bench conforms to the following standard: EN/ISO 20957 (Class H: Domestic Use)



Manual Contents.

Safety Information	03/04
<hr/>	
Assembly	05/07
Contents Checklist	05
Assembly Instructions	06/07
<hr/>	
Conditioning Guidelines	08/09
Beginner's Guide to Exercise	09
Stretching Guide	10/11
<hr/>	
Maintenance and Care	12
<hr/>	
Customer Support	13/14
Contact Information	13
Manufacturer's Warranty	14
<hr/>	
Technical Information	15/16
Parts List	15
Exploded Diagram	16
<hr/>	

Safety Information.

- Please read all the instructions carefully before using this product.
- Retain this manual for future reference.
- The specifications of this product may vary slightly from the illustrations and are subject to change without notice.

IMPORTANT SAFETY NOTICE:
note the following precautions before using the product.

- 01** Assemble the product exactly as per the instructions in this manual, using only the supplied tools to assemble it.
- 02** Check all the bolts, nuts and other connections before using the bench for the first time and ensure that it has been built correctly and is safe to be used.
- 02** This product is intended for home use only. Do not use the weight bench in any commercial, rental, or institutional setting.
- 03** Set up the bench indoors, in a dry place. Keep it away from moisture and water.
- 04** Place a suitable base (e.g. rubber mat, wooden board etc.) beneath it in the assembly area to protect it from dirt.
- 05** Choking hazard! Keep small parts and polybags away from children during and after assembly.
- 06** Place the weight bench on a stable and level surface with enough clearance around the bench (at least 0.6m in all directions).
- 07** Only use the bench for its intended purpose. It is not suitable for therapeutic or medical purposes.
- 08** The bench may only be used by one person at a time.
- 09** Always wear appropriate workout clothing when exercising. Aerobic shoes are required when using this equipment.
- 10** Periodically check all bolts, nuts and other connections to make sure that they are secure and in good working condition.
- 11** Damaged or worn parts may be dangerous for users and the integrity of the weight bench. Replace worn or damaged components immediately and do not use the bench until any issues have been resolved. Use only spare parts supplied by Viavito.
- 12** Unauthorized repairs or altering the bench's design or functions may be dangerous and will void the warranty.
- 13** DO NOT use attachments that are not recommended by the manufacturer.
- 14** WARNING! Inappropriate use of this machine such as while under the influence of drugs or alcohol, not in line with instructions or excessive usage, may result in serious injury or death.
- 15** Disabled persons should not use this equipment without a qualified person or physician in attendance.
- 16** Children and pets should be kept away from the weight bench at all times.
- 17** Maximum user weight is 100kg.
- 18** Maximum load (user + weights) is 200kg. Never overload the equipment.



WARNING: Before beginning using this equipment or doing any exercise program, consult your doctor. This is especially important for people over the age of 35 or those with pre-existing health problems.

Viavito assumes no responsibility for personal injury or property, and/or damage sustained by or through the use of this product.

SAVE THESE INSTRUCTIONS.

Assembly.

Contents Checklist

Before you begin the assembly, remove all of the contents from the box and make sure that you have all the parts listed and in correct quantities. This will ensure the quickest and most organized assembly.

Assembly may be easier if you have a set of wrenches. To avoid damaging parts, do not use power tools.

- Assembly requires two persons.
- The following tools (not included) maybe required for assembly:

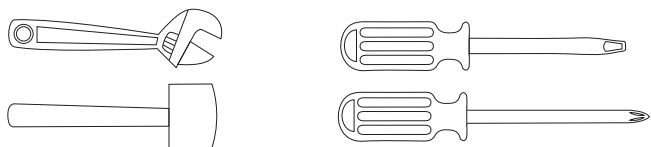

- 2 adjustable wrenches
- 1 rubber mallet
- 1 standard screwdriver
- 1 cross screwdriver

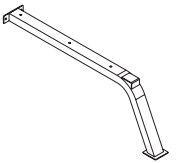
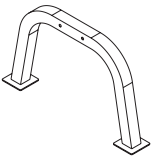
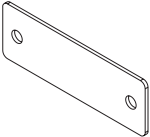
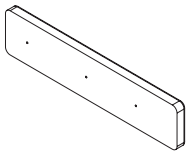
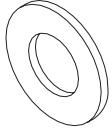
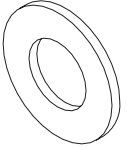
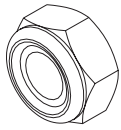
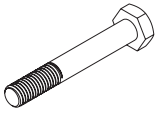
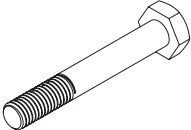
# 1  x1	# 2  x1	# 3  x1	# 4  x1	# 5 $\Phi 8$  x3
# 6 $\Phi 10$  x4	# 7 M10  x2	# 8 M8*65  x3	# 9 M10*75  x2	

Assembly Instructions

Find a clean and level surface to begin the assembly of your flat weight bench.

Step One.

- 01** Connect Main and Rear Frame using Flat Plate and Bolts with Washers. Tighten the bolts using another Washer and Lock Nut on the other side.

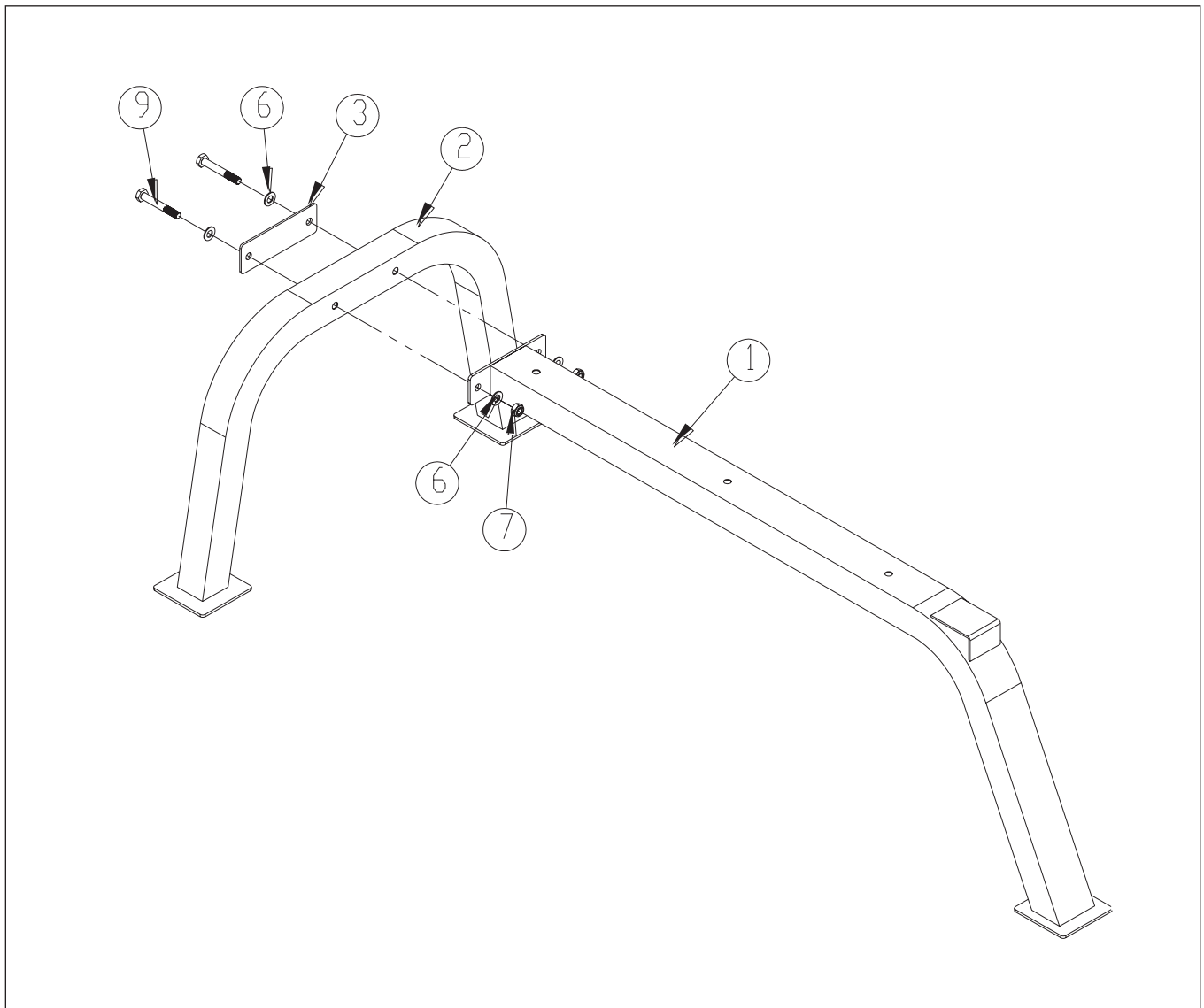

Step Two.

01 Attach Backrest to the frame using Bolts and Washers

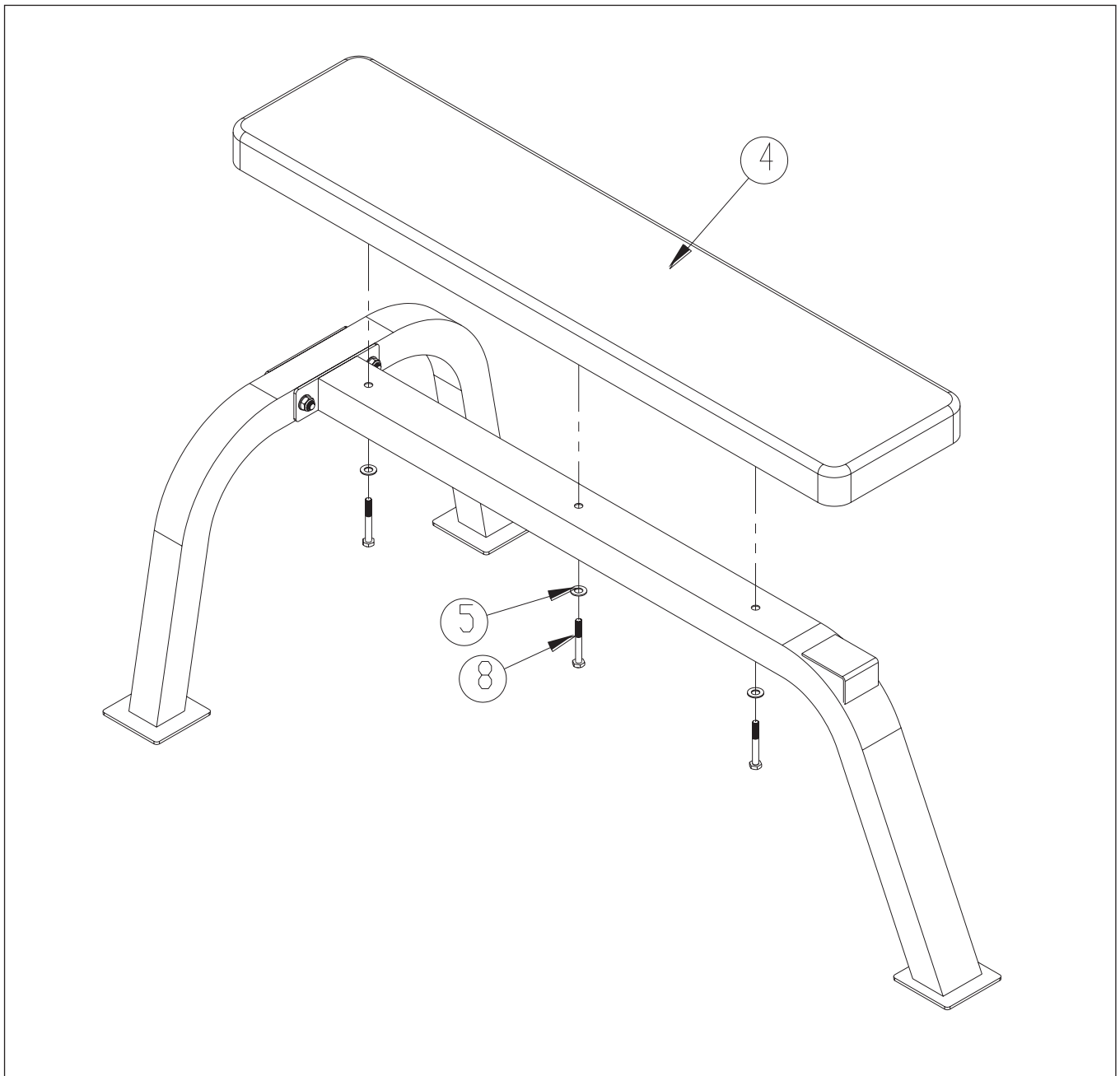

Conditioning Guidelines.

The following guidelines will help you to plan your exercise program and exercise safely. Remember that proper nutrition and adequate rest are essential for successful results.

WARNING: Before beginning this or any other exercise program consult your doctor. This is especially important for pregnant women and new mothers, all people over the age of 35, and those with medical problems such as heart disease, high or low blood pressure, injuries, joint problems, obesity and asthma.

Why exercise?

Exercise has been proven essential for good health and general wellbeing. Regular exercise will:

- Relieve tension and stress
- Provide enjoyment and fun
- Stimulate the mind
- Help maintain stable weight
- Control appetite
- Boost self-image
- Improve muscle tone and strength
- Improve flexibility
- Lower blood pressure
- Relieve insomnia

Beginner's Guide to Exercise

If you're beginning an exercise program for the first time or starting a new exercise program, you must check with your doctor that you are fit to do so, particularly if:

- You have been diagnosed with heart problems, high blood pressure or other medical conditions.
- You have not exercised for over a year.
- You are over 35 and do not currently exercise.
- You are pregnant or are a new mother.
- You have diabetes.
- You have chest pain, or experience dizziness or fainting spells.
- You are recovering from an injury or illness.

Workout tips

- Always perform a warm-up and stretching exercises before your workout and a cool-down and stretching exercises at the end.
- Start slowly and build up your time, speed and resistance gradually; doing too much too soon can lead to injuries.
- If you are sore or tired, give yourself a few extra days to recover.

How to begin

- Start with two or three 15-minute sessions per week with a rest day between workouts.
- Warm up for 5 to 10 minutes with gentle movements incorporating the whole body such as walking while swinging your arms in a circle and then stretch the muscles you'll use during your workout.
- Increase the intensity to slightly harder than comfortable and exercise for as long as you can. You may only be able to exercise for a few minutes at a time, but that will change quickly when you exercise regularly.
- End each workout with a 5-minute cool-down. You should then stretch the muscles you've just worked to develop flexibility, reduce muscle soreness and prevent injury.
- Increase your workout time by a few minutes each week until you can work continuously for 30 minutes per session.

How hard should you work?

Always be aware of how you feel when you exercise. If you feel dizzy or light-headed, stop immediately and rest.

Stretching Guide

Tips for stretching

- Begin with small mobility exercises of all the joints e.g. simply rotate the ankles, bend the knees and roll your hips. Gradually make the movements larger and faster. This will allow the body's natural lubrication (synovial fluid) to protect the surface of your bones at these joints.
- Always warm up the body before stretching, as this increases blood flow around the body, creating warmth which makes the muscles more supple.
- Start with your legs, and steadily work up the body.
- Each stretch should be held for at least 10 seconds (working up to 20 to 30 seconds) and usually repeated about 2 or 3 times.
- Do not stretch until it hurts. If there's any pain, ease off.
- Don't bounce. Stretching should be gradual and relaxed.
- Don't hold your breath during a stretch.
- Stretch after exercising to prevent muscles from tightening up.
- Stretch at least three times a week to maintain flexibility.

Warm-up

The purpose of warming up is to prepare your body for exercise and to minimise injuries. Warm up for five minutes before strength-training or exercising aerobically. Perform activities that raise your heart rate and warm the working muscles. Activities may include brisk walking, jogging, jumping jacks, jump rope, and running on the spot. Try to incorporate moves that take the joints through their full range of motion.

Stretching

Stretching while your muscles are warm after a proper warm-up and again after your strength or aerobic training session is very important. Muscles stretch more easily at these times because of their elevated temperature, which greatly reduces the risk of injury. Stretching develops flexibility and reduces muscles soreness.

Stretches should be held for 15 to 30 seconds.

Do not bounce or over-stretch. Take your time on each stretch. Gradually take each stretch a little deeper on every out breath to your personal maximum.



Side Stretch

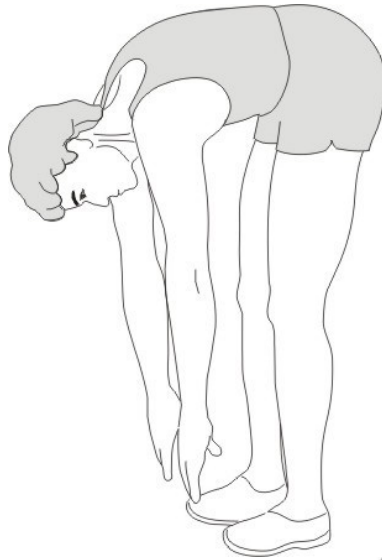

Toe Touch



Inner Thigh Stretch



Hamstring Stretch

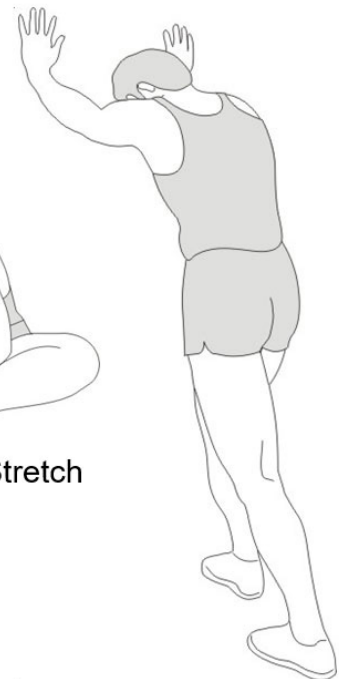

Calf-Achilles Stretch

COOL-DOWN

The purpose of cooling down is to return the body to its normal or near normal, resting state at the end of each exercise session. A proper cool-down slowly lowers your heart rate, allows blood to return to the heart and helps prevent muscle soreness caused by the build-up of lactic acid in the muscles.

Maintenance and Care.

- 01** We recommend placing the bench on a mat to protect both the equipment and your flooring.
- 02** Always keep the bench in a dry environment.
- 03** Use a warm, damp cloth to keep the product clean. Do not use aggressive cleaning products, such as detergents, to clean the bench. Remove drops of sweat from it immediately after finishing training.
- 04** Periodically check all bolts, nuts and other connections to make sure that they are secure and in good working condition.



Customer Support.

Contact Information

Should you require any assistance regarding this product please gather the following information and then contact us using the details below:

- Serial No. - This can be found on a label on the product itself
- Original purchase date
- Place of purchase
- Information about the place and conditions of use
- Precise description of the issue or defect.

IMPORTANT!! - Please retain your sales receipt. Viavito Customer Care may request proof of purchase to validate eligibility for warranty service. Warranty cover starts from the date shown on the proof of purchase.

VIAVITO®					
	UK CA	CE	Class H		Max = 100kg
www.viavito.com		Flat Bench		Max Load (User + Weights) = 200kg	
Viavito Ltd	EN/ISO 20957		Serial No:		
94 Cleveland Street London W1T 6NW					

The best way to contact us is via the website: **www.viavito.com**

Viavito Ltd
94 Cleveland Street
London
W1T 6NW

Email: **support@viavito.com**



<https://www.facebook.com/MyViavito>



<https://instagram.com/Viavito>



<https://twitter.com/MyViavito>

Manufacturer's Warranty

Viavito warrants this product to be free of defects of material and workmanship, under normal use and conditions, for a period of 12 months from the date of the original purchase

Terms.

This warranty extends only to the original purchaser and is not transferable.

The warranty does not cover:

- 01** Normal wear and tear
- 02** Any changes to upgrade this product from its normal state or use other than as described in the user manual
- 03** Damage resulting from:
 - a) Transport
 - b) Abuse, misuse, failure to follow instructions or improper or abnormal use
 - c) Non-home use - including commercial, professional, or rental purposes
 - d) Repairs not provided by Viavito
 - e) Accidents, lightning, water, fire, or any other causes beyond the control of Viavito
 - f) Improper location including, but not limited to, humid, dusty, or outdoor environments.

Viavito is not responsible or liable for direct, indirect, or consequential losses arising out of or in connection with the use of this product or damages with respect to any loss of property, revenue, profits, enjoyment or use, nor for any costs of removal or installation of this product.

This warranty covers products purchased as new inside the United Kingdom.

This warranty is in addition to and does not in any way affect your statutory rights.

Technical Information.

Parts List

No.	DESCRIPTION	Q'TY
#1	Main Frame	1
#2	Rear Frame	1
#3	Flat Plate	1
#4	Backrest Pad	1
#5	Washer ϕ 8	3
#6	Washer ϕ 10	4
#7	Hex Nylon Lock Nut M10	2
#8	Hex Bolt M8*65	3
#9	Hex Bolt M10*75	2

Exploded Diagram

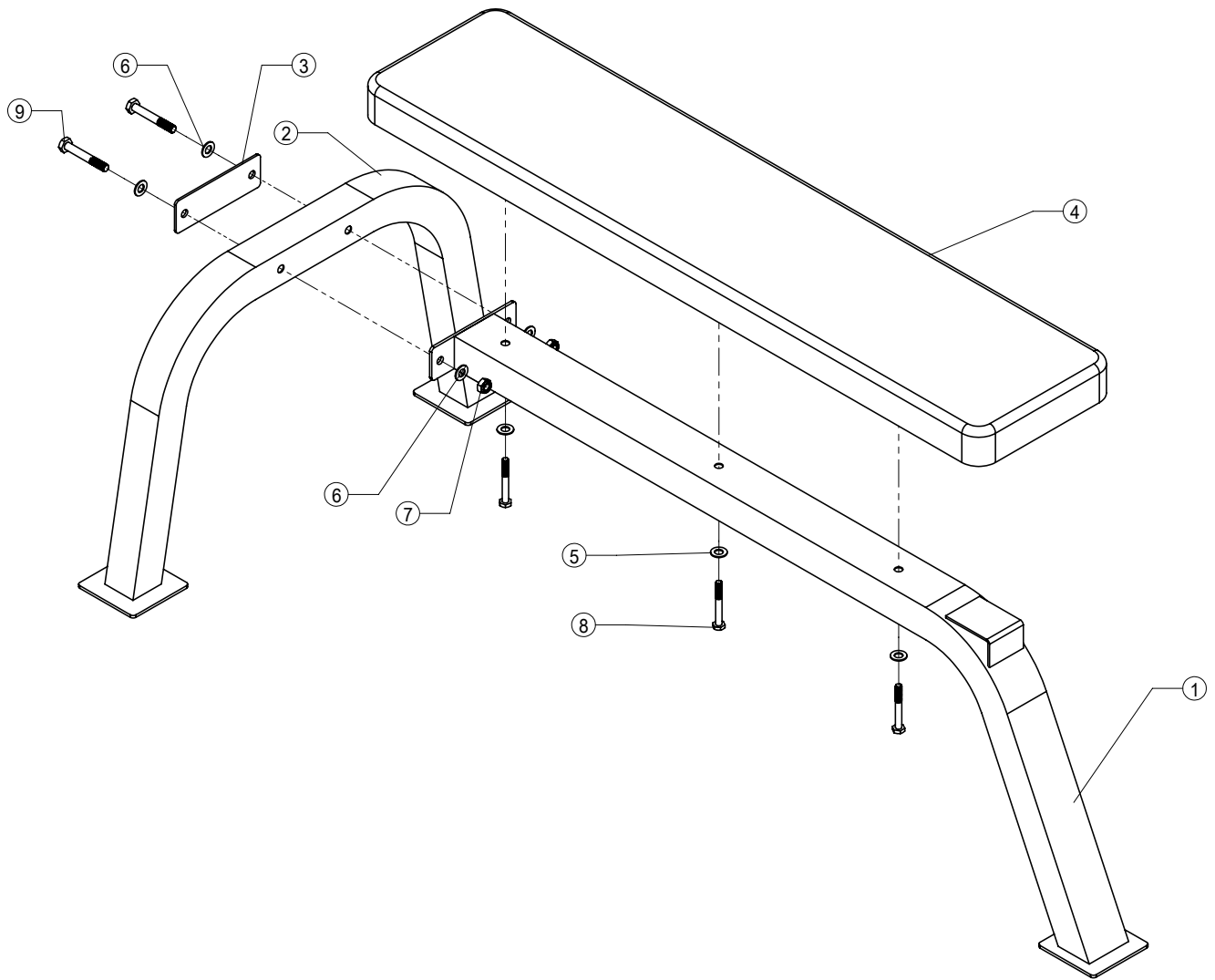

VIAVITO[®]