

VIAVITO[®]

Owner's Manual.

Outdoor Trampoline

www.viavito.com

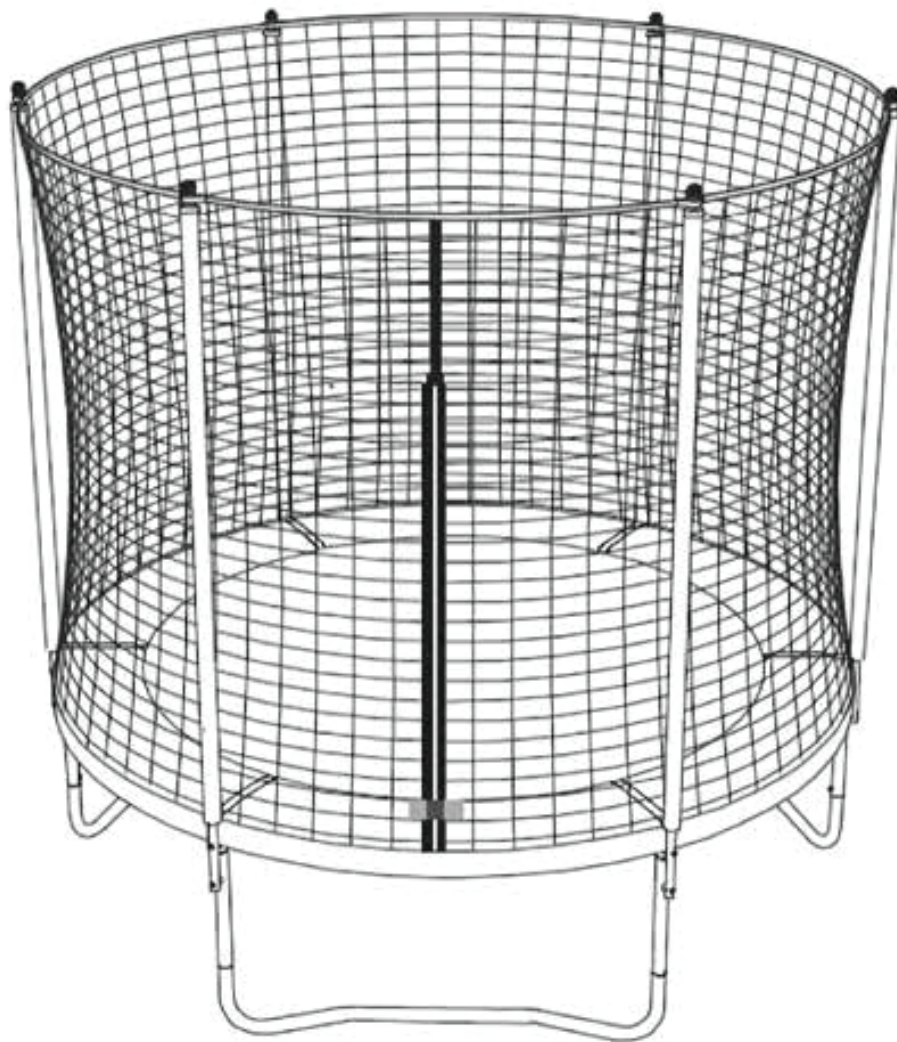



Congratulations on purchasing your very own Outdoor Trampoline.

You have chosen a high-quality, safe and innovative product, and we are certain it will keep you entertained for hours.

Please take the time to read this owner's manual as it will help you to get the most out of your new product.

For more information, or if you require any assistance please email us at **support@viavito.com**

Manual Contents.

Safety Information	02/07
<hr/>	
Assembly	08/13
<hr/>	
Assembly Instruction for Safety Enclosure	14/17
<hr/>	
Customer Support	18/19
<hr/>	
Contact Information	18
Manufacturer's Warranty	19

Safety Information.

Introduction

Before you begin use of this trampoline, be sure to carefully read all the information provided for you in this manual. Just like any other type of physical recreational activity, Participants can be injured. To reduce the risk of injury, be sure to follow appropriate safety rules and tips. Misuse and abuse of this trampoline is dangerous and can cause serious injury!

Trampoline, being rebounding devices, propel the performer to unaccustomed heights and into a variety of body movements.

Always inspect the trampoline before each use for wear-out mat, loose or missing parts.

Proper assembly, care and maintenance of product, safety tips, warnings, and proper

Techniques in jumping and bouncing are all included in this manual. All users and Supervisors must read and familiarize themselves with these instructions. Anybody who chooses to use this trampoline must be aware of their own limitations in regards to performing various jumps and bounces with this trampoline.

Warning



NO MORE THAN ONE PERSON AT A TIME ON THE TRAMPOLINE! MULTIPLE JUMPERS INCREASE THE RISK OF INJURY



DO NOT PERFORM SOMERSAULTS (FLIPS AS THIS WILL INCREASE YOUR CHANCES OF LANDING ON YOUR HEAD OR NECK)

Max users' weight: 50kgs for 3-legs 6' trampoline; 100kgs for 4-legs 8' trampoline, 150kgs for 10'-16' trampoline.

Do not attempt or allow somersaults, Landing on the head or neck can cause serious injury, paralysis, or death, even when landing in the middle of the bed.

Do not allow more than one person on the trampoline. Use by more one person at the same time can increase the chance of injury.

Use trampoline only with mature, knowledgeable supervision.

Do not attempt or allow somersaults. Serious injuries, paralysis, or death may result.

Do not allow more than one person on the trampoline at a time.

Use trampoline only with mature, knowledgeable supervision.

Not recommended for children under 6 years of age.

Inspect before use. Keep frame padding in place.

Climb on and off the trampoline. Do not use the trampoline as a springboard.

Stop bounce by flexing knees as feet come in contact with the bed.

Learn fundamental bounce and body positions thoroughly.

Avoid bouncing too high. Maintain control.

While keeping the head erect, focus eyes on the trampoline toward the perimeter.

Bounce in the center of the bed.

Avoid bouncing when tired.

Secure the trampoline against unauthorized use.

Keep objects away which could interfere with the performer.

Do not use the trampoline while under the influence of alcohol or drugs.

For equipment information, contact manufacturer or instructor.

For skill training information, contact a trainer certification organization.

Do not use when trampoline is wet or in windy conditions.

Read instructions before use.



**ALWAYS CONSULT A PHYSICIAN BEFORE PERFORMING ANY KIND OF PHYSICAL ACTIVITY.
PLEASE RETAIN THIS INFORMATION FOR FUTURE REFERENCE**

Information on use of the trampoline

Initially, you should get accustomed to the feel and bounce of the trampoline. The focus must be on the fundamentals of your body position and you should practice each bounce (the basic bounces) until you can do each skill with ease and control.

To brake a bounce, all you need to do is flex your knees sharply before they come in contact with the mat of the trampoline. This technique should be practiced while you are learning each of the basic bounces. The skill of braking should be used whenever you lose balance or control of your jump.

Always learn the simplest bounce first and be consistent with the control of your bounce before moving on to more difficult and advanced bounces. A controlled bounce is one when your take off point and landing point is the same spot on the mat. If you move up to the next bounce without first mastering the previous, you increase your chances of getting injured.

Do not bounce on the trampoline for extended periods of time because fatigue can increase your chances of becoming injured. Bounce for a brief period of time and then allow others to join in on the fun! Never have more than one person bouncing on the trampoline.

Jumpers should wear t-shirt, shorts or sweats, and regulation gymnastics shoes, heavy socks, or be barefoot. If you are just beginning, you may want to wear long sleeve shirts and pants to protect against scrapes and abrasions until you master correct landing positions and form. Do not wear hard sole shoes, such as tennis shoes, on the trampoline as this will cause excessive wear on the mat material.

You should always mount and dismount properly in order to avoid injury. To mount properly, you should PLACE your hand on the frame and either step or roll up onto the frame, over the springs, and onto the trampoline mat. You should always remember to place your hands onto the frame while mounting or dismounting. Do not step directly onto the frame pad or grasp the frame pad. To dismount properly, move over to the side of the trampoline and place your hand onto the frame as a support and step from the mat to the ground. Smaller children should be assisted when mounting and dismounting the trampoline.

Do not bounce recklessly on the trampoline since this will increase your chances of getting injured. The key to safety and having fun on the trampoline is control and mastering the various bounces. Never try to out-bounce another bouncer in terms of height! Never use the trampoline alone without supervision.

Accident classification

Mounting and Dismounting: Be very careful when getting on and off the trampoline. DO NOT mount the trampoline by grabbing the frame pad, stepping onto the springs, or by jumping onto the mat of the trampoline from any object (i.e. a deck, roof, or ladder). This will increase your chances of getting injured! DO NOT dismount by jumping off the trampoline and landing on the ground regardless of the makeup of the ground. If small children are playing on the trampoline, they may need help in mounting and dismounting.

Use of Alcohol or Drugs: DO NOT consume any alcohol or drugs when using this trampoline! This will increase your chances of getting injured since these foreign substances impairs your judgements, reaction time, and overall physical coordination.

Multiple Jumpers: If you have multiple jumpers (more than one person on the trampoline at any one time), you increase the chance of getting injured. Injuries could occur when you fly off the trampoline, lose control, collide with the other jumper(s), or land on the springs. Generally, the lightest person on the trampoline will get injured.

Striking the Frame or Springs: When playing on the trampoline, STAY in the center of the mat. This will reduce your risk of getting injured by landing on the frame or springs. Always keep the frame pad covering the frame of the trampoline. DO NOT jump or step onto the frame pad directly since it was not intended to support the weight of a person.

Loss of Control: DO NOT try difficult manoeuvres, or any manoeuvres until you have mastered the previous manoeuvre, or if you are just learning how to jump on a trampoline. If you do, you will increase your risk of getting injured by landing on the frame, springs, or off the trampoline completely because you might lose control of your jump. A controlled jump is considered landing on the same spot that you took off from. If you do lose control when you are jumping on the trampoline, bend your knees sharply when you land and this will allow you to regain control and stop your jump.

Somersaults (Flips): DO NOT PERFORM somersaults of any type (backwards or forwards) on this trampoline. If you make a mistake when trying to perform a somersault, you could land on your head or neck.. This will increase your chances of getting your neck or back broken, which will result in death or paralysis.

Foreign Objects: DO NOT use the trampoline if there are pets, other people, or any objects underneath the trampoline. This will increase the chances of an injury occurring. DO NOT hold any foreign objects in your hand and DO NOT place any objects on the trampoline while anyone is playing on it. Please be aware of what is overhead when you are playing on the trampoline. Tree limbs, wires, or other objects located over the trampoline will increase your chances of getting injured.

Poor Maintenance of Trampoline: A trampoline in poor condition will increase your risk of getting injured. Please inspect the trampoline before each use for bent steel tubes, torn mat, loose or broken springs, and overall stability of the trampoline.

Weather Conditions: Please be aware of the weather conditions when using the trampoline. If the mat of the trampoline is wet, the jumper could slip and injure him or herself. If it is too windy, jumpers could lose control.

Limiting Access: When the trampoline is not in use, always store the access ladder in a secure place so that unsupervised children cannot play on the trampoline.

Tips to reduce the risk accidents

Jumper's role in accident prevention

The key here is to stay in control of your jumps. DO NOT move onto more complicated, more difficult manoeuvres until you have mastered the basic, fundamental bounce.

Education is also key to safety and very important. Read, understand, and practice all safety precautions and warnings prior to using the trampoline. A controlled jump is when you land and take off from the same location. For additional safety tips and instructions, contact a certified trampoline instructor.

Supervisor's Role in Accident Prevention

Supervisor need to understand and enforce all safety rules and guidelines. It is the responsibility of the supervisor to provide knowledgeable advice and guidance to all jumpers of the trampoline. If supervision is unavailable or inadequate, the trampoline could be stored in a secure place, disassembled to prevent unauthorized use, or covered with a heavy tarpaulin that can be locked or secured with lock or chains. The supervisor is also responsible to ensure that the safety placard is placed on the trampoline and that jumpers are informed of these warnings and instructions.

Trampoline safety instructions

CARE AND MAINTENANCE:

Inspect the trampoline before each use and replace any worn, defective or missing parts. The following conditions could represent potential hazards:

Missing, improperly positioned, or insecurely attached the frame padding

Punctures, frays, tears, or holes worn in the bed or frame padding

Deterioration in the stitching or fabric of the bed or frame padding

Ruptured springs

A bent or broken frame

A sagging bed

Sharp protrusions on the frame or suspension system

JUMPERS:

Trampolines over 20in.(51cm) tall are not recommended for use by children under 6 year of age

Do not use trampoline if you have consumed alcohol or any drugs.

Remove all hard sharp objects from person before using trampoline.

You should climb on and off in a controlled and careful manner. Never jump on or off the trampoline and never use the trampoline as a device to bounce onto or into another object.

Always learn the basic bounce and master each type of bounce before trying more difficult types of bounces.

Review the Basic Skills Section to learn how to do the basics.

To stop your bounce, flex your knees when you land on the mat with your feet

Always be in control when you are bouncing on the trampoline. A controlled jump is when you land at the same spot that you took off from. If at any time you feel out of control, try to stop your bouncing.

Do not jump or bounce for prolonged periods of time or too high for a number of jumps

Keep your eyes on the mat to maintain control. If you do not, you could lose balance or control

Never have more than 1 person on the trampoline at any time

Always have a supervisor watching you when you are on the trampoline

For additional information concerning the trampoline equipment, contact the manufacturer.

SUPERVISORS:

Educate yourself with the basic jumps and safety rules. To prevent and reduce the risk of injuries, enforce all safety rules and ensure that new jumpers learn the basic bounces before trying more difficult and advanced jumps.

All jumpers need to be supervised, regardless of skill level or age.

Never use the trampoline when it is wet, damaged, dirty, or worn out. The trampoline should be inspected before any jumpers start bouncing on it.

Keep all objects that could interfere with the jumper away from the trampoline. Be aware of what is overhead, underneath, and around the trampoline.

To prevent unsupervised and unauthorized use, the trampoline should be secured when not in use.

Trampoline placement

The minimum overhead clearance required is 24 feet (7.3 meters). In terms of horizontal clearance, please ensure that no hazardous objects are near the trampoline such as tree limbs, other recreational objects (i.e. swing sets, swimming pools), electrical power wiring, walls, fences, etc.

For safe use of the trampoline, please be aware of the following when selecting a place for your trampoline:

Make sure it is placed on a level surface

The area is well-lighted

There are no obstructions beneath the trampoline

If you do not follow these guidelines, you increase the risk of someone getting injured.

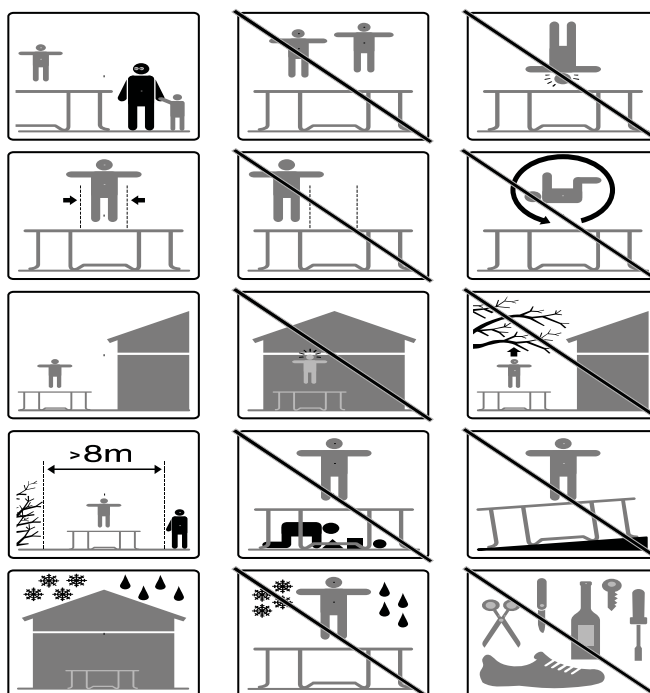

Lesson plan

The following lessons are suggested in order to learn basic steps and bounces before moving onto more difficult, complicated bounces. Before actually getting on and using the trampoline, you should read and understand all safety instructions. A complete discussion and demonstration of body mechanics and trampoline guidelines should occur between the supervisor and student as well.

Lesson 1

- A. Mounting and Dismounting - Demonstration of proper techniques
- B. The Basic Bounce-Demonstration and practice
- C. Braking (Check the Bounce) - Demonstration and practice. Learn to brake on command
- D. Hands and knees - Demonstration and practice. Stress should be on four- point landing and alignment

Lesson 2

- A. Review and practice of techniques learned in Lesson 1
- B. Knee Bounce-Demonstration and practice. Learn the basic down to knee and back up before trying half twist to left and right
- C. Seat Bounce -Demonstration and practice. Learn basic seat bounce then add a knee bounce, hands and knees; repeat.

Lesson 3

- A. Review and practice skills and techniques learned in previous lessons
- B. Front Drop-To avoid mat burns and teach the front bounce position, all students should be requested to assume the prone position (face down on the ground) while the instructor checks for faulty positions that could cause injury.
- C. Start with a hands and knees bounce and then extend body into prone position, land on the mat and return to feet
- D. Practice Routine-Hands and knees Bounce, Front Bounce, back to feet, seat bounce, back to feet.

Lesson 4

- A. Review and practice skills and techniques learned in previous lessons
- B. Half-Turn
 - i. Start from front drop position and as you make contact with the mat, push off with arms in either the right or left direction and turn head and shoulders in same direction.
 - ii. During turn, be sure to keep back parallel to mat and head up.
 - iii After completing turn, land in front drop position

After completing this lesson, the student now has a basic foundation of trampoline bounces. Jumpers should be encouraged to try and develop their own routines with the emphasis on control and form.

A game that can be played in order to encourage students to try and develop routines is "BOUNCE". In this game, players count from 1 to X. Player one starts with a maneuver. Player two has to do Player One's maneuvered and adds on another. Player Three does the maneuvers of one and Two and then adds a third maneuver. This continues until a player cannot do the routine until someone spells out the word "BOUNCE". The last remaining contestant is deemed the winner! Even when playing this game, it is important to perform your routines under control and not try difficult or highly skilled bounces that you have not yet mastered. A certified trampoline instructor should be contacted to further develop your trampoline skills.

Basic trampoline bounces

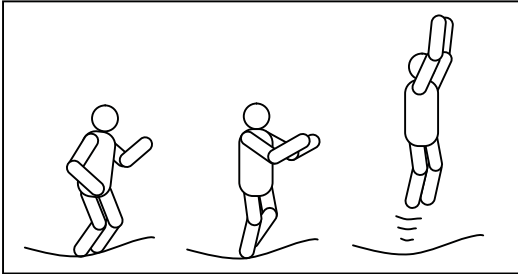

THE BASIC BOUNCE

1. Start from standing position, feet shoulder width apart and with head up and eyes on mat.
2. Swing arms forward and up and around in a circular motion.
3. Bring feet together while in mid-air and point toes downward
4. Keep feet shoulder width apart when landing on mat.

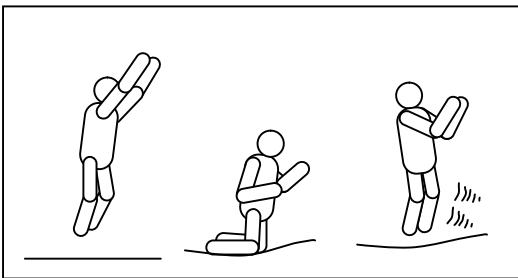

KNEE BOUNCE

1. Start with basic bounce and keep it low.
2. Land on knees keeping back straight, body erect and use your arms to maintain balance.
3. Bounce back to basic bounce position by swinging arms up.

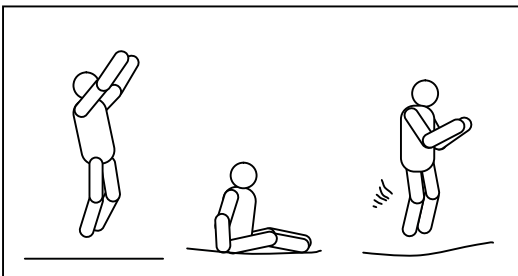

SEAT BOUNCE

1. Land in a flat sitting position.
2. Place hands on mat besides hips
3. Return to erect position by pushing with hands.

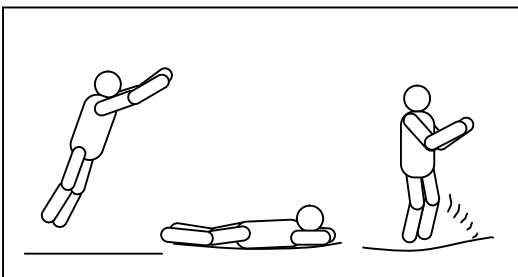

FRONT BOUNCE

1. Start with front bounce position
2. Land in prone (face down) position and keep hand and arms extended forward on mat.
3. Push off the mat with arms to return to standing position.

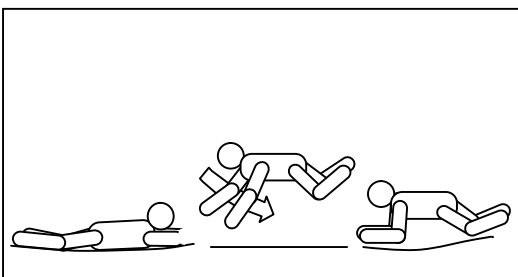

180 DEGREE BOUNCE

1. Start with front bounce position
2. Push off with left or right hands and arms (depending on which way you wish to turn).
3. Maintain head and shoulders in the same direction and keep back parallel to mat and head up.
4. Land in prone position by return to standing position by pushing up with hands and arms

Assembly.

To assemble this trampoline all you need is our special spring loading tool provided with this product. During periods of non-use. This trampoline can be easily disassembled and stored. Please read the assembly instructions before beginning to assemble the product.

Prior to assembling

Please refer to page for part descriptions and numbers. The assembly steps use these descriptions and numbers as reference for your convenience.

Make sure that you have all parts listed. If you are missing any parts, please refer to page for Instructions on how to attain any parts.

To prevent any injuries to your hands from pinch points during assembly, please use gloves to protect your hands.

Part List

Please select your trampoline size.

Reference Number	Part Number	Description	6'	8'	10'	12'	13'	14'	15'
1	TX01	Top rail with legsockets	6	6	6	8	8	8	12
2	TX02	Leg base	3	3	3	4	4	4	6
3	TX03	Vertical Leg Extensions	6	6	6	8	8	8	12
4	TX04	Frame pad	1	1	1	1	1	1	1
5	TX05	Trampoline mat, stitched with V-Rings	1	1	1	1	1	1	1
6	TX06	Galvanized springs	36	48	54	72	80	88	96
7	TX07	Safety Instruction Placard	1	1	1	1	1	1	1

REMEMBER TO USE GLOVES DURING ASSEMBLY TO AVOID PINCHING AND IT WILL TAKE AT LEAST TWO PEOPLE TO ASSEMBLE THE TRAMPOLINE



STEP 1 – Frame Layout

Please select your OWN tubing parts' quantity according to the products in your hand from following illustrations. All parts with the same part # are interchangeable and have not "right" or "left" orientation, to connect the parts, simply slide section tubing that is smaller on one end into the adjacent section that has a larger opening. These joints are called "connector points"

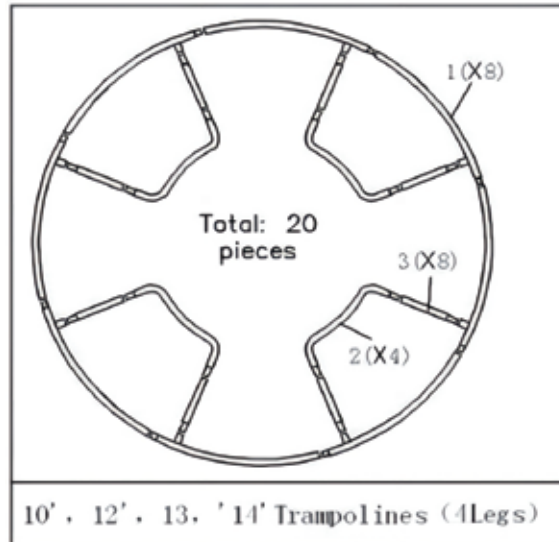
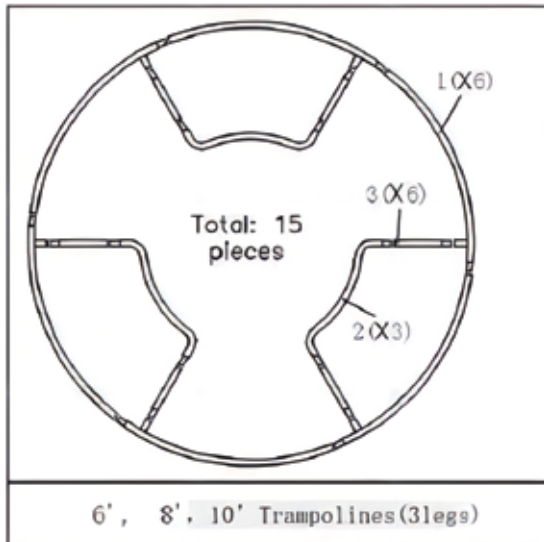

STEP 2 - Support Assembly

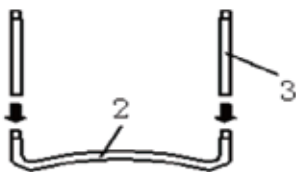

Slide all Vertical Leg Extensions (3) onto the Leg Base (2) as shown

STEP 3- Top Rail Assembly

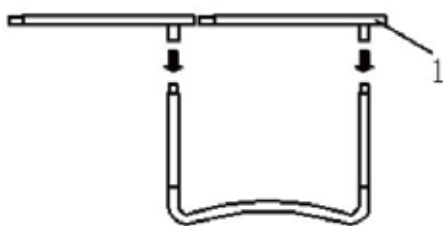

Two people will be necessary at this point to assemble the trampoline. One person lifts the Support Assembly from step 1 to a standing (vertical) position and inserts one of the sockets of the Top Rail with Sockets (1) into the Vertical Leg Extension portion of the Support Assembly. The other person holds the other end and inserts that portion into the other Support Assembly as shown. You should now have 2 Support Assemblies held together by 1 Top Rail with Socket.

STEP 4

After STEP 3, the tubes will look like Fig.5. Then using a second person connect as in Fig. 6

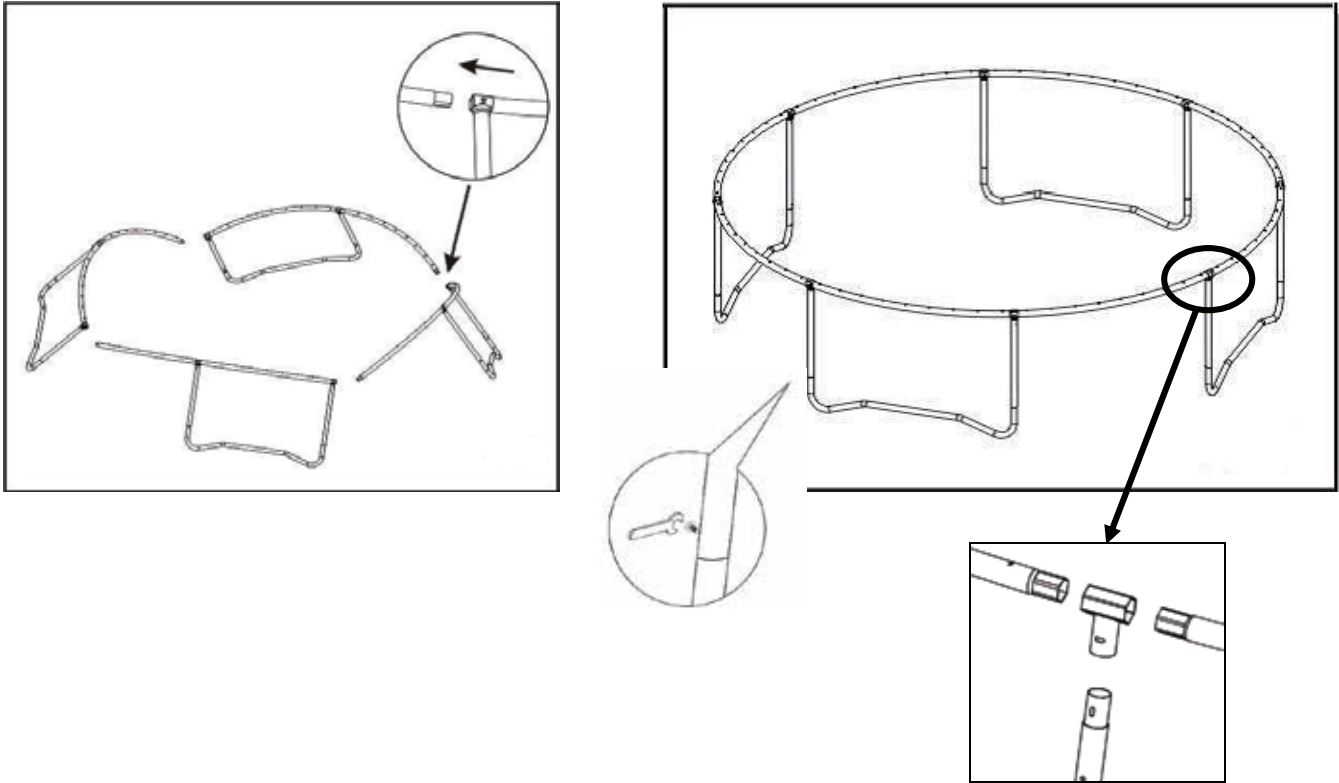

STEP 5 - Trampoline Mat Assembly

When Attaching springs to the trampoline mat, Please be careful. You will need another person to help you with this portion of the assembly. CAREFUL-When attaching the springs, the Connector Points can become pinch points since the trampoline is tightening up.

A. Lay out the Trampoline Mat (1) inside the frame

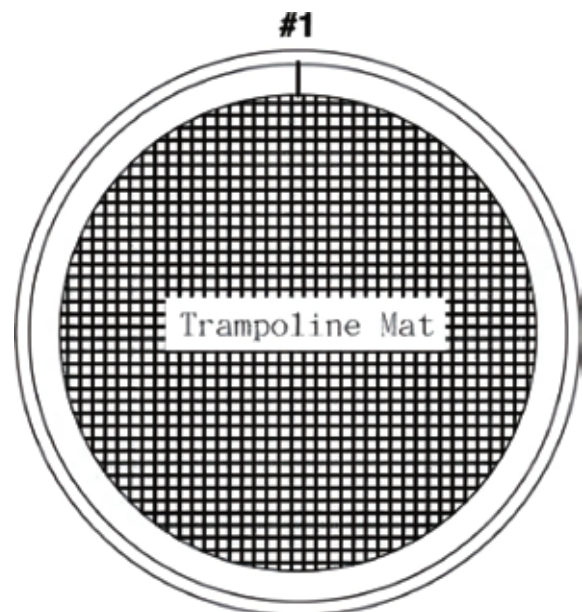

B. How to use the spring special tool.

STEP I : Position the spring on the eyelet of the jumping mat, attach tool and link up to the end of the spring hook.

STEP II : Extend spring tool and link up spring hook to the hole on the trampoline frame.

Please be careful where you place your hands and other parts of your body during spring assembly as connector points become pinch points!

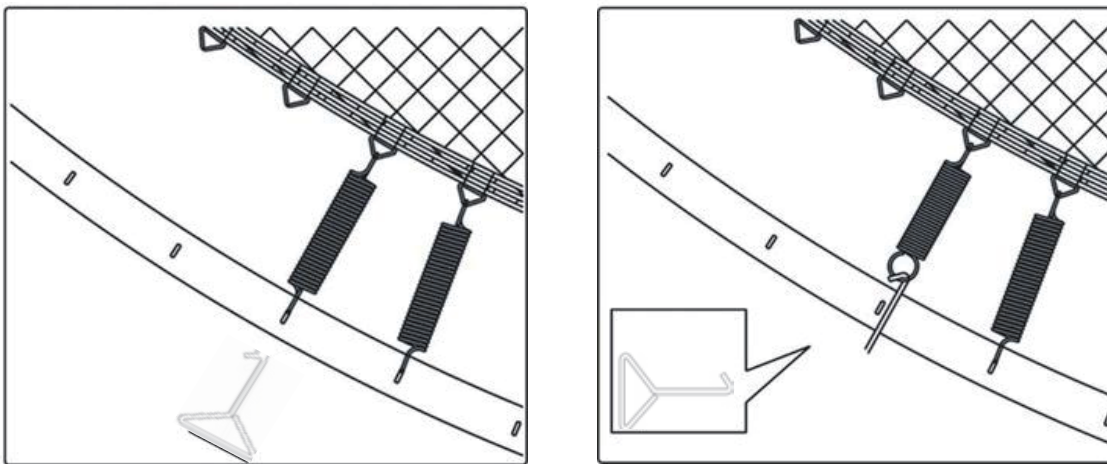

C. Select your spring quantity.

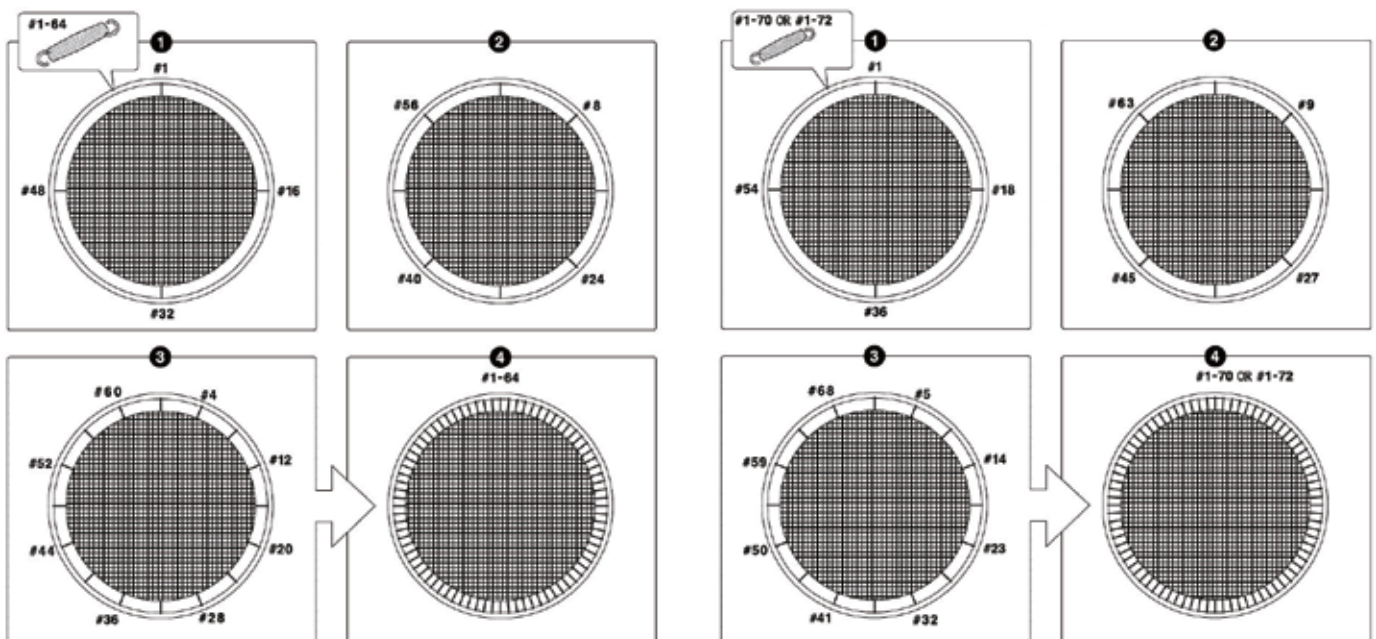

D. If you notice that you have skipped a hole and V Ring connection, recount and remove or attach any springs required to maintain the count of springs.

STEP 6-Safety placard Attachment

Using the tie wrap, attach the Safety Instruction Placard (7) to the trampoline. The tie wrap should go around the Vertical Frame joint and the Top Rail to ensure that it doesn't slide off the trampoline.

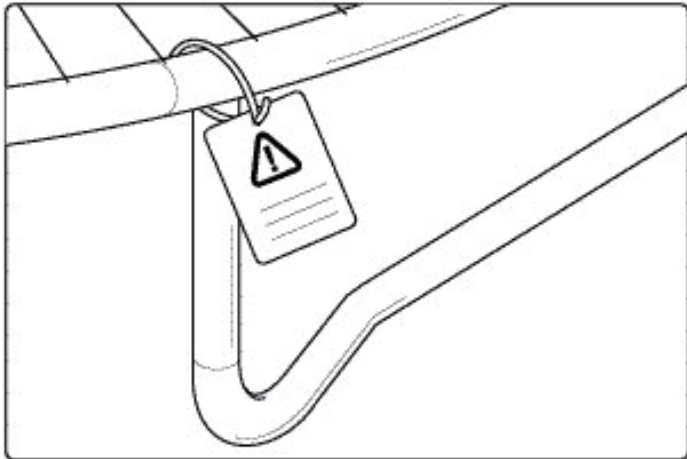

STEP 7-Frame Pad Assembly

A. Attaching the frame pads securely to the frame and in the proper position prior to use the trampoline

B. Lay the Frame Pad (4) over the trampoline so that the springs and the steel frame is covered.

Please ensure that the Frame Pad covers all metal parts.

C. Connect the elastic bands located under side of the frame or the springs. Check your pad model assembled fully.

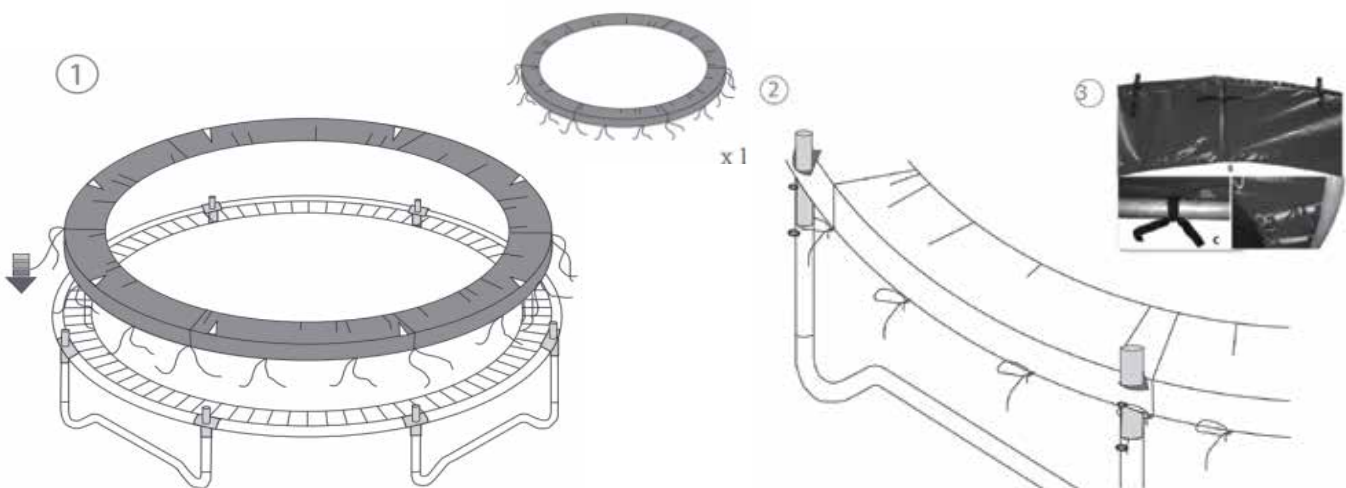

Care And Maintenance

This trampoline was designed and manufactured with quality materials and craftsmanship. If proper care and maintenance is provided, it will provide all jumpers with years of exercise, fun, and enjoyment as well as reduce the risk of injury. Please follow the guidelines listed below:

This trampoline is designed to withhold a certain amount of weight and use. Please make sure that only one person at any one time uses the trampoline. Jumpers should either wear socks, gymnastics shoes, or be barefoot when using the trampoline. Please be aware that street shoes or tennis shoes should NOT be worn while using the trampoline. In order to prevent the trampoline mat from getting cut or damaged please do not allow any pets onto the mat. Also, jumpers should remove all sharp objects from their person prior to using the trampoline. Any type of sharp or pointed objects should be kept off the trampoline mat at all times.

Always inspect the trampoline before each use for worn, abused or missing parts. A number of conditions could arise that may increase your chances of getting injured. Please be aware of:

Punctures, holes, or tears in the trampoline mat

Sagging trampoline mat

Loose stitching or any kind of deterioration of the mat

Bent or broken frame parts, such as the legs

Broken, missing, or damaged springs

Damaged, missing, or insecurely attached frame pad

Protrusions of any types (especially sharp types) on the frame, springs, or mat

IF YOU FIND ANY OF THE PREVIOUS CONDITIONS, OR ANYTHING ELSE THAT YOU FEEL COULD CAUSE HARM TO ANY USER, THE TRAMPOLINE SHOULD BE DISASSEMBLED OR SECURED FROM USE UNTIL THE CONDITION(S) HAS BEEN RESOLVED.

WINDY CONDITIONS

In severe wind situations, the trampoline can be blown about. If you expect windy weather conditions, the trampoline should be moved to a sheltered area or disassembled. Another option is to tie the round, outside portion (top frame) of the trampoline to the ground using ropes and stakes. To ensure security, at least three(3) tie downs should be used. Do not just secure the legs of the trampoline to the ground because they can pull out the frame sockets.

MOVING THE TRAMPOLINE

If you need to move the trampoline, two people should be used. All connector points should be wrapped secured with weather resistant tape, such as duct tape. This will keep the frame intact during the move and prevent the connector points from dislocating and separating. When moving, lift the trampoline slightly of the ground and keep it horizontal to the ground. For any type of other move, you should disassemble the trampoline.

Assembly Instruction for Safety Enclosure.

Part list

Reference Number	Description	6/8/10'	10/12/13/14	15'
1	Upper pole A	6pcs	8pcs	12pcs
2	Upper pole B	6pcs	8pcs	12pcs
3	Bar Spacers	12pcs	16pcs	24pcs
4	Curved Washers	12pcs	16pcs	24pcs
5	Screws	12pcs	16pcs	24pcs
6	Nuts	12pcs	16pcs	24pcs
7	Pole Cover	6pcs	8pcs	12pcs
8	CAP	6pcs	8pcs	12pcs
9	Safety Net	1pc	1pc	1pc

Diagram for Parts

1. Upper pole A 

2. Upper pole B 

3. Bar Spacers 

4. Curved Washers 

5. Screws 

6. Nuts 

7. Pole Cover 

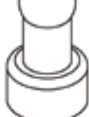
8. Cap 

9. Safety Net 

Assembly Instruction

WARNING: READ AND FOLLOW THIS INSTRUCTION, PRIOR TO ASSEMBLE AND USE OF THIS EQUIPMENT.

STEP 1: CONNECT TWO SECTIONS OF UPPER POLES TOGETHER AS SHOWN IN FIGURE 1. PUT A CAP AT THE TOP OF THE POLES.



FIGURE 1



FIGURE 2



FIGURE 3

STEP 2: REPEAT STEP 1 UNTIL ALL THE POLES ARE SET UP.

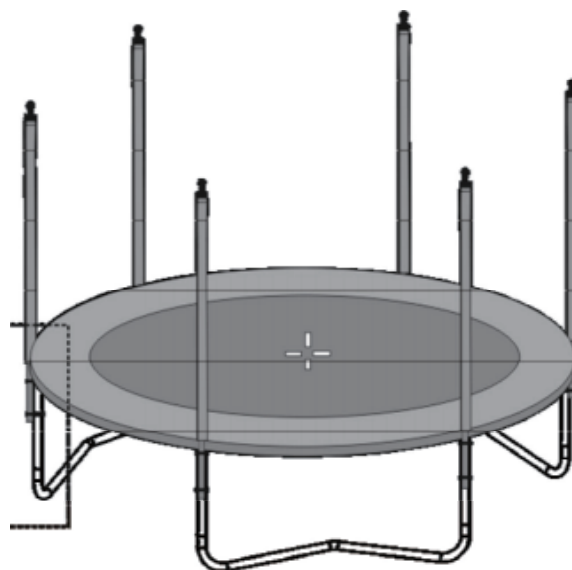
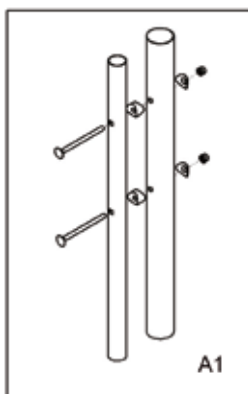

FIGURE 4



A1

A1: Mount the upper poles onto the vertical leg extension using parts of spacer, washer, screw, and nut.



A2

A2: Firm the bolt using the wrench

VIAVITO®

STEP 3: Spread safety net (#9) out on the trampoline mat. Locate the panel with the doorway and align the net as to where you would like to get in and out of the trampoline. The edge with the pre-sewn hanging loop on the upper part of the net will be hooked at the top of the pole. (See B)



STEP 4

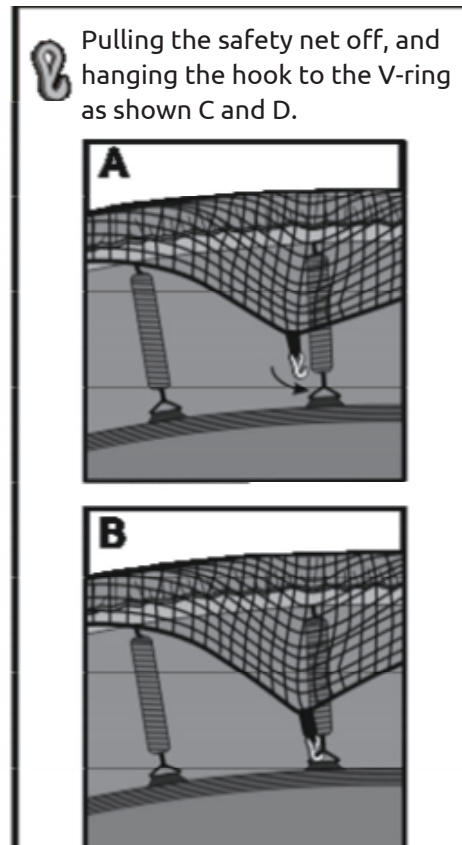
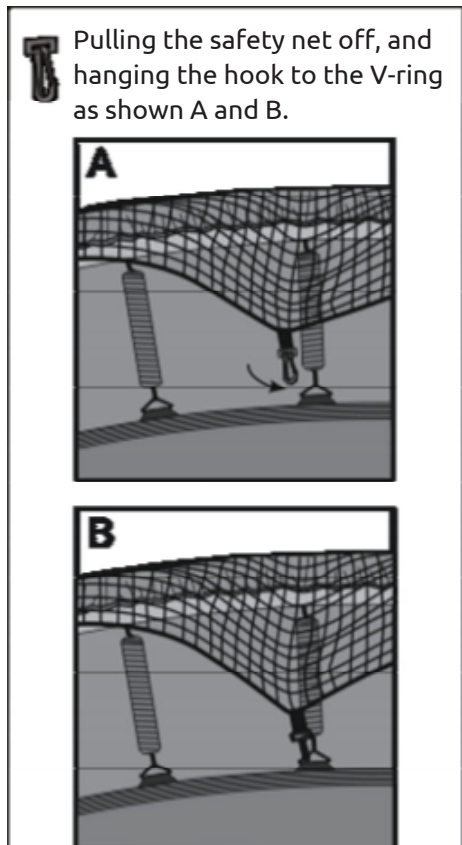

STEP 5: Hook to the V-ring as order as figure 6.

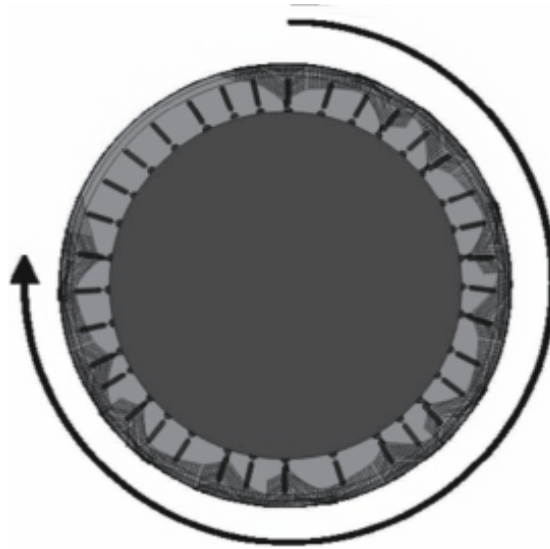

FIGURE 6

STEP 6: When you set up as same as figure 7. You need more force to pull down the net (may be need two adults help). So the net will very tight for trampoline.

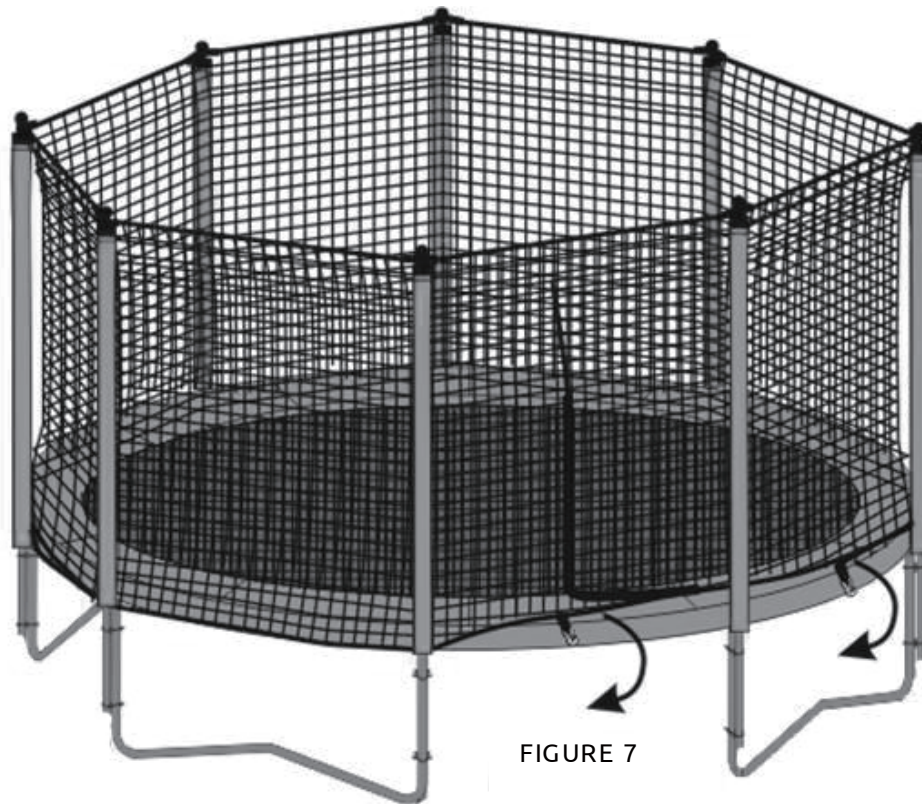

FIGURE 7

IMPORTANT WARNING!
YOU SHOULD GO BACK NOW AND STRETCH ALL ATTACHMENT HOOKS TIGHT AND DOUBLE CHECK TO SEE WHETHER YOU HAVE FASTENED THE SCREW AND BOLT OR NOT, SO THE SAFETY NET STANDS STIFF. OTHERWISE, THE SAFETY NET WILL NOT FUNCTION PROPERLY. THEN FINISH ASSEMBLING.

Customer Support.

Contact Information

Should you require any assistance regarding this product please gather the following information and then contact us using the details below:

- Original purchase date
- Place of purchase
- Information about the place and conditions of use
- Precise description of the issue or defect.

IMPORTANT!! - Please retain your sales receipt. Viavito Customer Care may request proof of purchase to validate eligibility for warranty service. Warranty cover starts from the date shown on the proof of purchase.

The best way to contact us is via the website: **www.viavito.com**



<https://www.facebook.com/MyViavito>



<https://instagram.com/Viavito>



<https://twitter.com/MyViavito>

The best way to contact us is via the website: **www.viavito.com**

Sweatband.com Ltd t/a Viavito

Unit 5, Mill Square

Featherstone Road

Wolverton Mill

Milton Keynes

MK12 5ZD

Email: **support@viavito.com**

CARDIOfitness GmbH & Co. KG

Friedrich-Ebert-Str. 75

51429 Bergisch Gladbach

Service@cardiofitness.de

Manufacturer's Warranty

Viavito Ltd warrants this product to be free of defects of material and workmanship, under normal use and conditions, for a period of 12 months from the date of the original purchase.

Warranty extensions may apply to this product subject to registering this product with Viavito. To qualify for this, please complete the warranty registration form on the Viavito website at **www.viavito.com**. Full details of warranty extensions and the Viavito Manufacturer's Warranty are available online at **www.viavito.com**

Terms.

This warranty extends only to the original purchaser and is not transferable. The warranty does not cover:

- 01** Normal wear and tear
- 02** Any changes to upgrade this product from its normal state or use other than as described in the user manual
- 03** Damage resulting from:
 - a) Transport
 - b) Abuse, misuse, failure to follow instructions or improper or abnormal use. Non-home use - including commercial, professional, or rental purposes
 - c) Repairs not provided by Viavito Ltd
 - d) Accidents, lightning, water, fire, or any other causes beyond the control of Viavito

- e) Improper location including, but not limited to, humid, dusty, or outdoor environments.

Viavito is not responsible or liable for direct, indirect, or consequential losses arising out of or in connection with the use of this product or damages with respect

to any loss of property, revenue, profits, enjoyment or use, nor for any costs of removal or installation of this product.

This warranty covers products purchased as new inside the United Kingdom.

In the event of the machine requiring a repair, this may need to be performed at a Viavito authorised repair centre.

This warranty is in addition does not in any way affect your statutory rights.